

Amateur Radio General Class License Class Syllabus

For July 1, 2019 to June 30, 2023 Question pool

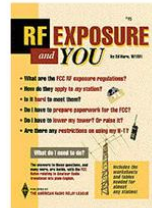

This syllabus contains everything you will need to know to pass your Amateur Radio General Class License exam

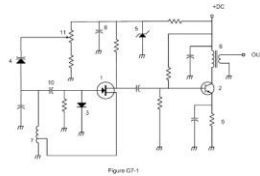
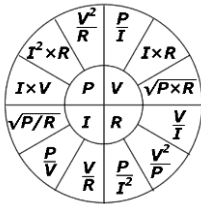
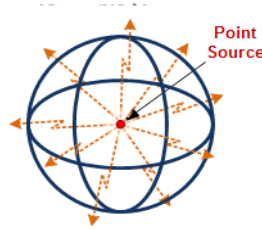
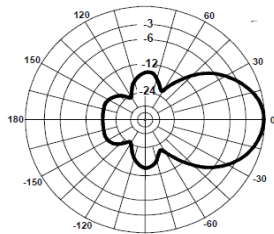
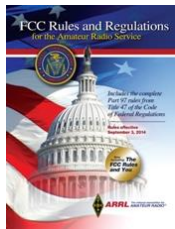

General License Class Syllabus

For July 1, 2019 to June 30, 2023

With March 15, 2019 errata

All questions are shown in this syllabus are exactly as they will appear in the exam with only the correct answer shown **(in green bold text)**. Question numbers have been included so you can go to the ARRL General Class License Manual, or the published question pool itself at <http://ncvec.org/page.php?id=364> to see the additional choices in the exam for each question.

This material is based on the published 2019 General Class License question pool, effective July 1, 2019, with additional information added by the author *(in italicized blue text)*.

Many of the illustrations used in this syllabus were copied from the ARRL Handbook CD-ROM, scanned from the license manual with permission from the copyright owner, ARRL, as well as other public sites on the web. This document has been written to assist students and instructors and may be distributed freely as long as no charge for the material is made (except for reproduction costs associated with delivering paper copies or electronic copies on CD-ROM's or other media) and this note of copyright permission is not removed. This syllabus is copyrighted by the Author

An electronic file for this syllabus may downloaded from www.ad7fo.com. It is recommended that if this is posted to another web site and that only the web page be referenced to be sure the latest revision is always downloaded.

Additional information and resources to help you study for the Technician Class License can be found on the ARRL web site (www.arrl.net). The ARRL web site has articles, resources and reference materials on all aspects of the exam questions and Amateur Radio in general.

About the Author



Education: Electrical Engineering, Penn State University

Work Experience:

Hewlett Packard: (retired in 2004)

- Twenty-three years at the RF Products Division in Spokane WA – 1981 to 2004 - Regional Sales Support, Application Engineering, World Wide Sales Management, Systems Development and Product Management
- Eleven years at Valley Forge PA sales office, from 1969 until 1981 - Engineering Technical Support, Technical Customer Training and Field Sales Engineer

American Electronics Laboratories:

- Nine years working in and managing a Metrology (Calibration) Laboratory in Colmar Pennsylvania. Responsible for a team of Technicians that maintained a wide range of test instruments and their calibration traceability to the National Bureau of Standards (*NBS*) [now the National Institute of Standards and Technology (**NIST**)].

Jerrold Electronics:

- Two years as a Technician at the Jerrold Electronics R&D Laboratory in Hatboro, PA working on RF test equipment and cable TV equipment.

Hobbies:

- Amateur Radio (Extra Class License Holder)
- Test Equipment
- Electronics in general.

Amateur Radio Activities:

- Teaching and mentoring
- Developing and teaching Technician, General and Extra License Classes
- Developed and teach ARRL EMCOMM class with a power point presentation I have developed.
 - Wrote and presented more than twenty, one-hour or less technical talks for local ham radio clubs (Many are available from the Authors web page www.ad7fo.com).
 - Provide a radio and general-purpose test table every year at the Spokane Hamfest for folks to test their radios and other electronic Hamfest treasures.
- Attending as many Pacific Northwest Hamfest's as I can

ARRL Appointments:

- ARRL EWA Section Manager
- ARRL VE (Volunteer Examiner)
- ARRL Technical Specialist for Spokane area
- ARRL Registered Instructor
- ARRL Certified EMCOMM instructor

Other:

- Member of the Inland Empire VHF Club
- Member of the Spokane County ARES/RACES
- Member of Greater Spokane County COAD (Community Organizations Active in Disasters)
- Member of the Annual Spokane Hamfest Planning committee

Syllabus Overview

The Syllabus is intended either for classroom study or for self-study in pursuit of the Amateur Radio General Class License and to assist instructors in teaching a class. It may be distributed freely if no charge for the material is made. Reproduction costs associated with delivering paper or electronic copies on CD-ROM's may be charged and **the note of copyright permission on page 2 is not removed.**

Any modified copies must contain a note that the original material by the author has been modified and contain the name and contact information of the person making the changes. An MS Word version is available from the Author at ad7fo@arrl.net for those who want to customize this material for classes they teach.

Question numbers are shown in bold text like this, **T1A03** so you can go to the ARRL Technician Class License Manual, or the question pool itself, to see the actual questions and other answer choices that will be in the exam. If there is an FCC (Federal Communications Commission) **Part 97 rule** relating to the answer it is shown following the question number. The FCC regulation reference number like this, **T1A07 [97.3(a)(45)]**

All questions are shown with only the correct answer **in bold green text**, which in the authors view makes it easier when you see the other choices on your exam to identify the correct answer because you have not seen the wrong answers.

Additional information has been added by the author (*in italicized blue text*) for some of the questions to explain the answer or show calculations. In addition, some graphics have also been added for additional clarification.

A copy of the ARRL General Class License Manual is not required. Everything you need to study for your license exam is in this syllabus. The author recommends if you want more technical background that you acquire a copy of the ARRL Handbook (available from ARRL web site or other retailers and book stores). The Handbook will cover your technical needs for all three licenses and will be a great reference after you are licensed. And at a cost of approximately \$50 (a recent copy will suffice if you find a used one at a Hamfest).

While every effort was made to insure the accuracy of the material herein, this material was prepared by an ordinary human being, and it is likely that a few typographical and other errors remain. Author welcomes corrections and can be contacted at ad7fo@arrl.net

You can check the author's web site www.ad7fo.com to insure you have the latest revision of the syllabus.

Requirements for Students

1. You will need a printed or down loaded copy of this syllabus to study from prior to the class. The Class will be taught directly from a PowerPoint version of the syllabus. The syllabus can be downloaded from www.ad7fo.com. A printed, and bound copy of this syllabus can be purchased from The UPS Store located at 2910 East 57th Avenue #5, Spokane, WA 99223, Phone (509) 448-6368 (ask for Richard, KE7DQC) for around \$15. These can be picked up at the store or can be ordered and shipped to a student's address. All the possible questions in the exam are covered in this syllabus.

2. A copy of Part 97 of the FCC rules is recommended and a PDF version can be downloaded for free from the ARRL website at <http://www.arrl.org/part-97-amateur-radio> or purchased in printed form from the ARRL Web site or other sources. The FCC rules require that you to have access to a copy of the part 97 rules (printed copy or on line from your computer) after you receive your license.

3. You will need a basic scientific calculator that you are familiar with operating that is capable of normal math functions, square roots, trigonometry and Base 10 Log functions (all basic scientific calculators have these functions). Not all these functions are needed for the General Exam but will be needed when you go for the Extra exam. Scientific calculators like the Texas Instruments TI30 are available from office supply stores for around \$20 or less from office supply stores if you do not already have one. **It is recommended you do not purchase a programmable calculator as it will not be allowed in the test session. Cell phone calculators are never allowed in test sessions.**

4. A desire to learn and to ask questions. If you do not understand something that is being taught be sure you ask the instructor.

5. You must take and pass the General Class written exam (element 3)

- There are 35 questions on the exam. All questions are multiple choice (4 choices).
- Questions only come from the published Question Pool (all possible questions are covered in this syllabus).
- The number of possible questions for each topic area is fixed and shown for each question group in the test.
- You must have 26 correct answers to pass the exam (no more than 9 incorrect answers).
- There are online practice sites with the real test questions previously listed where you can take practice exams. Listed below are a few sites where you can find practice exams:

<http://aa9pw.com/radio/>

<http://www.arrl.org/exam-practice>

<http://www.eham.net/exams>

<http://www.hamradiation.com>

<http://www.qrz.com/hamtest>

<http://www.hamexam.org>

<http://www.hamstudy.org>

<http://www.hamradiolicenseexam.com>

6. You should read through this syllabus before the class. You are not expected to learn and understand everything you read, but by being familiar with what will be covered, you can identify those areas where you need to focus on and/or bring up questions during the class. Do not be intimidated. The material will be made easy to understand by your instructor(s). You can check for ham radio clubs in your area for a local Ham (known as Elmer's) that can help you prepare.

ELECTRICAL AND ELECTRONIC BASICS

(Background for the technical portion of the exam)

Metric system Basics for Ham Radio

Giga **XXXX** = 1,000,000,000 (one thousand million) **XXXX**

Mega **XXXX** = 1,000,000 (one million) times **XXXX**

Kilo **XXXX** = 1,000 (one thousand) **XXXX**

Centi **XXXX** = 1/100 (one hundredth) **XXXX**

Milli **XXXX** = 1/1,000 (one thousandth) **XXXX**

Micro **XXXX** = 1/1,000,000 (one millionth) **XXXX**

Nano **XXXX** = 1/1,000,000,000 (one thousandth of a Micro) **XXXX**

Pico **XXXX** = 1/1,000,000,000,000 (one millionth of a millionth) **XXXX**

Example: **XXXX** is the value you are expressing such as Volts, Amperes, Ohms, Watts, etc. One Kilo**volt** would be 1,000 Volts, one mega**ohms** would be 1,000,000 ohms

Voltage, Resistance and Current Flow:

Everything we use in our amateur station requires a power source that delivers a specific **Voltage** and **Current**. *Voltage* is commonly referred to as *Electro Motive Force (EMF)* instead of volts. This is like the water pressure in a dam. Current, the flow of electricity, is measured in *amperes* and is commonly represented by the letter **I**. Current is like the flow of water in a pipe at the bottom of the dam. The amount of water flowing (**current**) would be limited by the diameter of the pipe (**resistance**) and the pressure (**Voltage/EMF**) exerted by the height of the water in the dam. In an electronic circuit the current flow would be limited by the EMF (**voltage**) and the resistance to current flow (**resistor**) measured in ohms.

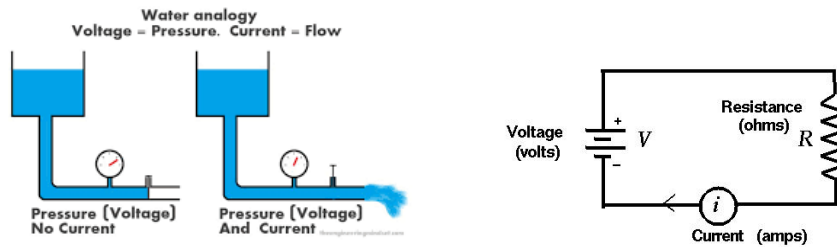

If we know the voltage and the resistance in a circuit, we can calculate the current that would be flowing using the following expression:

Current in amperes (I) is equal to the EMF in volts (E) divided by the resistance in ohms (R).

$$I \text{ (amperes)} = E \text{ (voltage)} \div R \text{ (resistance)}$$

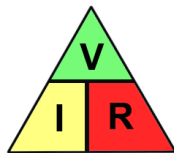

For example: if you have a 12-volt battery connected across a 6-ohm resistor the current flowing would be 2 amperes.

$$\text{Current} = V \div R \text{ or } 12 \text{ volts} \div 6 \text{ Ohms or Current} = 2 \text{ amperes}$$

Power:

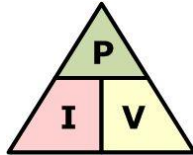

Power is work done by electricity and is defined as the voltage across a circuit multiplied by the current flowing through the circuit.

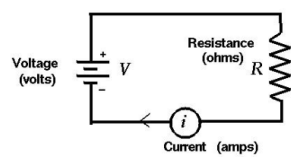

Examples:

A circuit connected to 120-volt power outlet that draws 10 amperes would be consuming 1200 watts of power.

$$\text{Power} = \text{voltage times the current or Power} = 120 \times 10 \text{ or } 1200 \text{ watts}$$

A circuit powered by a 12-volt battery that draws 200 milliamperes (ma) would consume 2.4 watts.

$$\text{Power} = \text{voltage times the current or Power} = 12 \times 0.20 \text{ or } 2.4 \text{ watts}$$

We have two kinds of commonly encountered sources of electric power:

Direct Current:

Direct Current (DC) is a voltage that has two terminals, one positive and one negative. Typically, DC power is available from batteries, accessory jacks in vehicles, and plug-in power supplies

Commonly used batteries for amateur radio applications include the following:

Alkaline and Zinc Carbon cells that produce 1.5 V - available in AAA, AA, C and D cells. **These batteries are not rechargeable.**



Lithium batteries that produce 1.5 or 3 volts. A typical example would be AAA, AA and coin cells. **These batteries are not rechargeable.**



Nickel Cadmium (NICAD), Nickel Metal Hydride (NIMH) batteries that produce 1.2 volts, and are available in AAA, AA, C, D cells, and custom shapes. **These batteries are rechargeable.**



Flooded Lead Acid batteries that produce 12 volts. Examples are automotive batteries and deep cycle marine batteries. These contain a liquid electrolyte (sulfuric acid) and cannot be used tipped over, laid on their side. **These batteries are rechargeable.** These batteries contain Sulphuric acid and release Hydrogen gas while charging so ventilation is required.

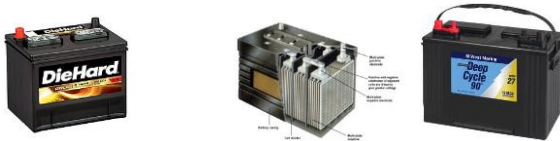

Sealed Lead Acid batteries – Gel Cells and AGM (Absorbed Glass Mat) batteries that are available in 12-volt versions (other Voltages are available bur for Amateur Radio the 12-volt version is the most commonly used). They are sealed and use a “gelled” electrolyte and they can be operated in any position. They have high current ratings ranging from smaller ones with a 1 ampere hour rating up to 80 ampere hours and more. **These batteries are rechargeable.**



Alternating Current

Alternating current is a voltage that alternates between equal positive and negative values. This is what is available from the common AC wall outlet in our homes.

The 120 Volts from the outlets in our home is the equivalent of a value that would provide the same heating effect (or work) as a DC voltage of the same value. voltage and is known as the RMS (root Mean Square) value of the AC voltage. The heating effect of AC is less than the peak value because the voltage is continuously changing over the time for each cycle. The peak value of an AC RMS voltage is **1.414 times the RMS value**. Therefore, the peak voltage for a 120 Volt RMS coming from the outlet in our homes would be 1.414 times 120 volts or **169.68 volts Peak** or **339.36 volts peak to peak** (measured from the positive peak to the negative peak of the AC waveform).

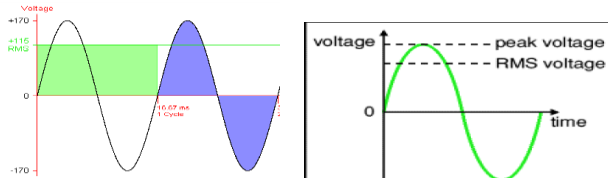

For a pure sine wave the equivalent RMS value is 0.707 times the peak value. Conversely the peak voltage can be calculated as 1.414 times the RMS Value.

Examples:

The peak voltage present in standard 120V RMS AC line voltage is $1.414 \times 120V$ or approx. 170 volts peak. The peak to peak (maximum negative to maximum positive peaks) would be two times the peak voltage or approx. 340 V Peak to Peak.

$$PP = 2x \text{ Peak } \text{ or } PP = 2x (120 \times 1.414) \text{ or } PP = 2 \times 169.7 \text{ or } PP = 339.4 \text{ Volts}$$

An AC voltage that reads 65 volts on an RMS meter will have a peak to peak voltage of 184 Volts.

$$\text{Peak to peak Voltage} = 2 \times \text{RMS} \times 1.414 \text{ or } PP = 2 \times 65 \times 1.414 \text{ or } PP = 183.8 \text{ V PP}$$

FREQUENCY:

If we start at the first positive peak to the next positive peak of one cycle of our sine wave you will observe that it crosses through Zero twice in the cycle.

The time it takes for one cycle of a sine wave is the period of the sine wave. A 100 Hz sine wave has a period of .01 Seconds (or 10 milliseconds).

Frequency is the number of times that an event happens in one second of time. Shown below is a single cycle of a sine wave, as it would be displayed on an oscilloscope. To determine its frequency, you would divide the time in seconds for one cycle into 1.00.

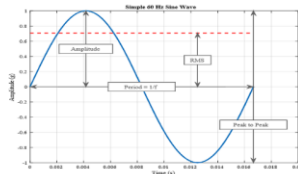

Examples:

What is the frequency of a sine wave with a 10 ms (millisecond) period for one cycle?

$F = 1 \div \text{time}$ or $F = 1 \div 0.010$ or $F = 100\text{Hz}$

What is the frequency of a sine wave with a 1 μs (microsecond) period for one cycle?

$F = 1 \div \text{time}$ or $F = 1 \div 0.000001$ or $F = 1,000,000 \text{ Hz}$ or 1 MHz

What is the frequency of a sine wave with a 15 μs period for one cycle?

$F = 1 \div \text{time}$ or $F = 1 \div 0.000015$ or $F = 66,666 \text{ Hz}$ or 66.666 KHz

What is the frequency of a sine wave with a 16.666 millisecond period for one cycle?

$F = 1 \div \text{time}$ or $F = 1 \div 0.0166$ or $F = 60.00 \text{ Hz}$

Wavelength:

Wavelength is the distance a wave will travel during one cycle usually expressed in meters. Light travels at a velocity of approximately 300 million meters per second (*actual speed of light is 299,792,458 meters every second*) in free space. Wavelength is important in amateur radio when designing and building antennas.

We frequently refer to the frequency bands in amateur radio by their approximate wavelength in meters. For instance, 146 Megahertz (MHz) would be the 2-meter band. Wavelength is easily calculated as using the following equation:

Wavelength equals the speed of light (in meters per second) divided by the frequency

$\text{Wavelength} = 300,000,000 \div \text{frequency in Hertz}$ or to simplify

$\text{Wavelength} = 300 \div \text{Frequency (in megahertz)}$

For the 146 MHz example above this would be:

$300,000,000 \text{ divided by } 146,000,000$; or since both values are in millions simply,

$300 \div 146$ or 2.054 meters

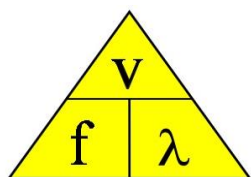

λ = wavelength

v = wave speed

f = frequency

This is an important relationship to remember since there are questions in the exam relating to wave length for a specific frequency or the frequency for a given wavelength.

In amateur radio we frequently refer to our frequencies in terms of approximate wavelength. Since we frequently operating in the megahertz band, we can simplify our conversion to wavelength by dividing the frequency in megahertz (MHz) into 300. For example:

A 146 MHz signal would be in the 2-meter band --- $300 \div 146 = 2.054\text{-meters}$

A 4.0 MHz signal would be in the 75-meter band --- $300 \div 4 = 75\text{-meters}$

A frequency of 1 MHz (1,000,000 Hertz) which is in the middle of the AM broadcast band will travel 300 meters in one complete cycle.

$300,000,000 \div 1,000,000$ or $300 \div 1$ or 300 meters

RF Signals and Modulation

Radio frequencies are simply sine waves like we see coming out of the outlet at home except at a much higher frequency (rate). Radio signals in the AM Broadcast band are operating from 500,000 hertz to 1,700,000 Hertz. This frequency range can be expressed in kilohertz (thousands of hertz as 500 KHz to 1,700 KHz), or in megahertz (millions of hertz) as 0.500 MHz to 1.700 MHz

The frequency of a signal is just the carrier frequency, that is the frequency with no information applied. When we add voice or data to the carrier we are “modulating” or adding information. Simple modulation can be accomplished by varying the frequency of the carrier (Frequency Modulation or FM) or varying the amplitude of the carrier amplitude (Amplitude Modulation or AM).

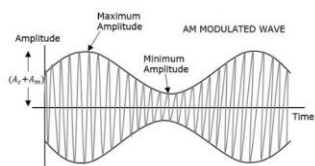

Amplitude Modulation (AM)

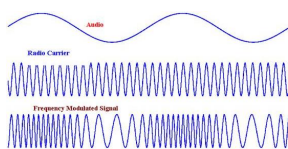

Frequency Modulation (FM)

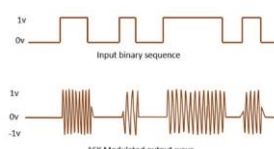

Digital Modulation

There are many other forms of modulation other than simple amplitude and frequency modulation used in Amateur Radio here are a few:

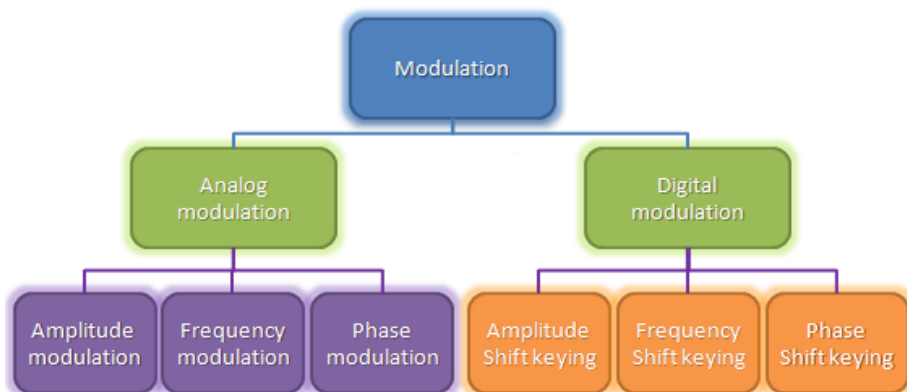

2019-2023 General Class – FCC Element 3 Syllabus – Effective July 1, 2019

Revision 1.2

SUBLELEMENT G1 – COMMISSION'S RULES [5 Exam Questions – 5 Groups]

G1A – General class control operator frequency privileges; primary and secondary allocations
G1B – Antenna structure limitations; good engineering and good amateur practice; beacon operation; prohibited transmissions; retransmitting radio signals
G1C – Transmitter power regulations; data emission standards; 60-meter operation requirements
G1D – Volunteer Examiners and Volunteer Examiner Coordinators; temporary identification; element credit
G1E – Control categories; repeater regulations; third-party rules; ITU regions; automatically controlled digital station

SUBLELEMENT G2 – OPERATING PROCEDURES [5 Exam Questions – 5 Groups]

G2A – Phone operating procedures; USB/LSB conventions; breaking into a contact; VOX operation (*1 exam question*)
G2B – Operating courtesy; band plans; emergencies, including drills and emergency communications (*1 exam question*)
G2C – CW operating procedures and procedural signals; Q signals and common abbreviations; full break-in (*1 exam question*)
G2D – Volunteer Monitoring Program; HF operations (*1 exam question*)
G2E – Digital operating procedures (*1 exam question*)

SUBLELEMENT G3 – RADIO WAVE PROPAGATION [3 Exam Questions – 3 Groups]

G3A – Sunspots and solar radiation; ionospheric disturbances; propagation forecasting and indices (*1 exam question*)
G3B – Maximum Usable Frequency; Lowest Usable Frequency; propagation (*1 exam question*)
G3C – Ionospheric layers; critical angle and frequency; HF scatter; Near Vertical Incidence Skywave (*1 exam question*)

SUBLELEMENT G4 – AMATEUR RADIO PRACTICES [5 Exam Questions – 5 groups]

G4A – Station operation and setup (*1 exam question*)
G4B – Test and monitoring equipment; two-tone test
G4C – Interference to consumer electronics; grounding; DSP (*1 exam question*)
G4D – Speech processors; S meters; sideband operation near band edges (*1 exam question*)
G4E – HF mobile radio installations; alternative energy source operation (*1 exam question*)

SUBLELEMENT G5 – ELECTRICAL PRINCIPLES [3 Exam Questions – 3 Groups]

G5A – Reactance; inductance; capacitance; impedance; impedance matching (*1 exam question*)
G5B – The decibel; current and voltage dividers; electrical power calculations; sine wave root-mean-square (RMS) values; PEP calculations (*1 exam question*)
G5C – Resistors, capacitors, and inductors in series and parallel; transformers (*1 exam question*)

SUBLELEMENT G6 – CIRCUIT COMPONENTS [2 Exam Questions – 2 Groups]

G6A – Resistors; capacitors; inductors; rectifiers; solid-state diodes and transistors; vacuum tubes; batteries (*1 exam question*)
G6B – Analog and digital integrated circuits (ICs); microprocessors; memory; I/O devices; microwave ICs (MMICs); display devices; connectors; ferrite cores (*1 exam question*)

SUBELEMENT G7 – PRACTICAL CIRCUITS [3 Exam Questions – 3 Groups]

- G7A – Power supplies; schematic symbols (*1 exam question*)
- G7B – Digital circuits; amplifiers and oscillators (*1 exam question*)
- G7C – Receivers and transmitters; filters; oscillators (*1 exam question*)

SUBELEMENT G8 – SIGNALS AND EMISSIONS [3 Exam Questions – 3 Groups]

- G8A – Carriers and modulation: AM; FM; single sideband; modulation envelope; digital modulation; overmodulation (*1 exam question*)
- G8B – Frequency mixing; multiplication; bandwidths of various modes; deviation; duty cycle; intermodulation (*1 exam question*)
- G8C – Digital emission modes (*1 exam question*)

SUBELEMENT G9 – ANTENNAS AND FEED LINES [4 Exam Questions – 4 Groups]

- G9A – Antenna feed lines: characteristic impedance and attenuation; SWR calculation, measurement, and effects; matching networks (*1 exam question*)
- G9B – Basic antennas (*1 exam question*)
- G9C – Directional antennas (*1 exam question*)
- G9D – Specialized antennas (*1 exam question*)

SUBELEMENT G0 – ELECTRICAL AND RF SAFETY [2 Exam Questions – 2 Groups]

- G0A – RF safety principles, rules and guidelines; routine station evaluation (*1 exam question*)
- G0B – Station safety: electrical shock, safety grounding, fusing, interlocks, wiring, antenna and tower safety (*1 exam question*)

US Amateur Radio Bands

US AMATEUR POWER LIMITS

On March 28, 2017, the Federal Communications Commission adopted rules that will allow Amateur Radio access to 472-479 kHz (850 meters) and to 150-151.9 kHz (230 meters). However, these frequencies are not available for use until the 2018 Report and Order is published in the Federal Register and the final rules are adopted. The 2018 Report and Order is expected to be published in the Federal Register in the next few months. The 2018 Report and Order will be published in the Federal Register in the next few months. The 2018 Report and Order will be published in the Federal Register in the next few months.

On March 28, 2017, the Federal Communications Commission adopted rules that will allow Amateur Radio access to 472-479 kHz (850 meters) and to 150-151.9 kHz (230 meters). However, these frequencies are not available for use until the 2018 Report and Order is published in the Federal Register and the final rules are adopted. The 2018 Report and Order is expected to be published in the Federal Register in the next few months. The 2018 Report and Order will be published in the Federal Register in the next few months. The 2018 Report and Order will be published in the Federal Register in the next few months.

On March 28, 2017, the Federal Communications Commission adopted rules that will allow Amateur Radio access to 472-479 kHz (850 meters) and to 150-151.9 kHz (230 meters). However, these frequencies are not available for use until the 2018 Report and Order is published in the Federal Register and the final rules are adopted. The 2018 Report and Order is expected to be published in the Federal Register in the next few months. The 2018 Report and Order will be published in the Federal Register in the next few months. The 2018 Report and Order will be published in the Federal Register in the next few months.

On March 28, 2017, the Federal Communications Commission adopted rules that will allow Amateur Radio access to 472-479 kHz (850 meters) and to 150-151.9 kHz (230 meters). However, these frequencies are not available for use until the 2018 Report and Order is published in the Federal Register and the final rules are adopted. The 2018 Report and Order is expected to be published in the Federal Register in the next few months. The 2018 Report and Order will be published in the Federal Register in the next few months. The 2018 Report and Order will be published in the Federal Register in the next few months.

On March 28, 2017, the Federal Communications Commission adopted rules that will allow Amateur Radio access to 472-479 kHz (850 meters) and to 150-151.9 kHz (230 meters). However, these frequencies are not available for use until the 2018 Report and Order is published in the Federal Register and the final rules are adopted. The 2018 Report and Order is expected to be published in the Federal Register in the next few months. The 2018 Report and Order will be published in the Federal Register in the next few months. The 2018 Report and Order will be published in the Federal Register in the next few months.

On March 28, 2017, the Federal Communications Commission adopted rules that will allow Amateur Radio access to 472-479 kHz (850 meters) and to 150-151.9 kHz (230 meters). However, these frequencies are not available for use until the 2018 Report and Order is published in the Federal Register and the final rules are adopted. The 2018 Report and Order is expected to be published in the Federal Register in the next few months. The 2018 Report and Order will be published in the Federal Register in the next few months. The 2018 Report and Order will be published in the Federal Register in the next few months.

On March 28, 2017, the Federal Communications Commission adopted rules that will allow Amateur Radio access to 472-479 kHz (850 meters) and to 150-151.9 kHz (230 meters). However, these frequencies are not available for use until the 2018 Report and Order is published in the Federal Register and the final rules are adopted. The 2018 Report and Order is expected to be published in the Federal Register in the next few months. The 2018 Report and Order will be published in the Federal Register in the next few months. The 2018 Report and Order will be published in the Federal Register in the next few months.

On March 28, 2017, the Federal Communications Commission adopted rules that will allow Amateur Radio access to 472-479 kHz (850 meters) and to 150-151.9 kHz (230 meters). However, these frequencies are not available for use until the 2018 Report and Order is published in the Federal Register and the final rules are adopted. The 2018 Report and Order is expected to be published in the Federal Register in the next few months. The 2018 Report and Order will be published in the Federal Register in the next few months. The 2018 Report and Order will be published in the Federal Register in the next few months.

On March 28, 2017, the Federal Communications Commission adopted rules that will allow Amateur Radio access to 472-479 kHz (850 meters) and to 150-151.9 kHz (230 meters). However, these frequencies are not available for use until the 2018 Report and Order is published in the Federal Register and the final rules are adopted. The 2018 Report and Order is expected to be published in the Federal Register in the next few months. The 2018 Report and Order will be published in the Federal Register in the next few months. The 2018 Report and Order will be published in the Federal Register in the next few months.

On March 28, 2017, the Federal Communications Commission adopted rules that will allow Amateur Radio access to 472-479 kHz (850 meters) and to 150-151.9 kHz (230 meters). However, these frequencies are not available for use until the 2018 Report and Order is published in the Federal Register and the final rules are adopted. The 2018 Report and Order is expected to be published in the Federal Register in the next few months. The 2018 Report and Order will be published in the Federal Register in the next few months. The 2018 Report and Order will be published in the Federal Register in the next few months.

On March 28, 2017, the Federal Communications Commission adopted rules that will allow Amateur Radio access to 472-479 kHz (850 meters) and to 150-151.9 kHz (230 meters). However, these frequencies are not available for use until the 2018 Report and Order is published in the Federal Register and the final rules are adopted. The 2018 Report and Order is expected to be published in the Federal Register in the next few months. The 2018 Report and Order will be published in the Federal Register in the next few months. The 2018 Report and Order will be published in the Federal Register in the next few months.



Effective Date for 2,200 and 630 Meters to be announced

KEY

Note: CW operation is permitted throughout all amateur bands.

MCW is authorized above 51 MHz, except for 144.0-144.1 and 219-220 MHz. Test transmissions are authorized above 51 MHz, except for 219-220 MHz.

■ = RTTY and data
■ = phone and image
■ = CW only
■ = SSB phone
■ = USB phone, CW, RTTY, and data
■ = Fixed digital message forwarding systems only

E = Amateur Extra
 A = Amateur
 G = General
 T = Technician
 N = Novice

See ARRL.MHz at www.arrl.org for detailed band plans.

ARRL We're At Your Service

ARRL Headquarters: 895 Park Street (Fax: 860-594-0299) email: arrl@arrl.org

Publication Dept: www.arrl.org Tel: 860-594-0300 email: arrl@arrl.org

Membership/Creation Desk: www.arrl.org/membership Tel: 860-594-0300 (ext. 504-0300) email: membership@arrl.org

Getting Started in Amateur Radio: Tel: 860-594-0300 (ext. 504-0305) email: membership@arrl.org

Events: 860-594-0300 email: ve@arrl.org

Copyright © ARRL, 2017 rev. 4/26/2017

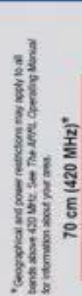
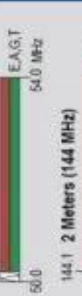

*Geographical and power restrictions may apply to all bands above 430 MHz. See The ARRL Operating Manual for information about your area.

All licenses except Novices are authorized all modes on the following frequencies:

3300-2310 MHz	10.0-10.5 GHz	122.35-123.0 GHz
2300-2450 MHz	24.0-24.25 GHz	134-141 GHz
3300-3500 MHz	47.0-47.2 GHz	241-250 GHz
9650-5005 MHz	76.0-81.0 GHz	All above 275 GHz

‡ No pulse emissions

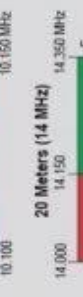
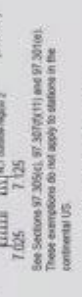

General, Advanced, and Amateur Extra licensees may operate on these five channels on a secondary basis with a maximum effective radiated power (ERP) of 100 W PEP relative to a half-wave dipole. Permitted operating modes include upper sideband voice (USB), CW, RTTY, PAK1 and other digital modes such as PACTOR II. Only one signal at a time is permitted on any channel.

SUBELEMENT G1 – COMMISSION’S RULES [5 Exam Questions – 5 Groups]

G1A – General class control operator frequency privileges; primary and secondary allocations

G1A01 [97.301(d)]

On which HF/MF bands is a General class license holder granted all amateur frequency privileges?
160 meters, 60 meters, 30 meters, 17 meters, 12 meters, and 10 meters

G1A02 [97.305]

On which of the following bands is phone operation prohibited? **30 meters**

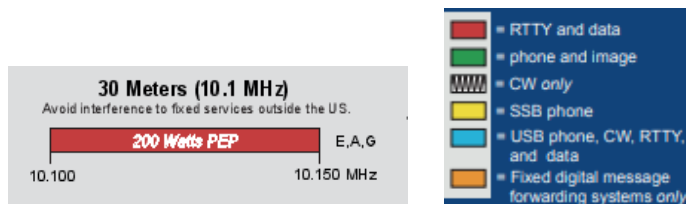

G1A03 [97.305]

On which of the following bands is image transmission prohibited? **30 meters**
See answer above

G1A04 [97.303 (h)]

Which of the following amateur bands is restricted to communication only on specific channels, rather than frequency ranges? **60 meters**

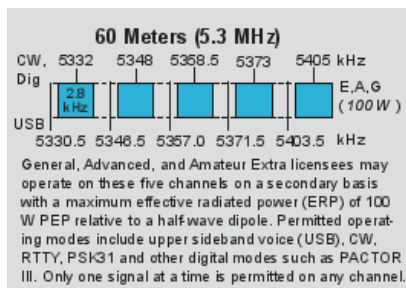

G1A05 [97.301(d)]

Which of the following frequencies is in the General class portion of the 40-meter band (in ITU Region 2)?

7.250 MHz

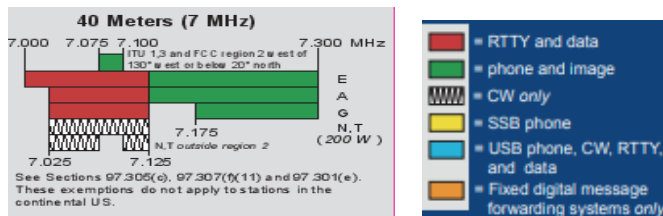

Commented [JT1]:

G1A06 [97.301(d)]

Which of the following frequencies is within the General class portion of the 75-meter phone band?

3900 kHz

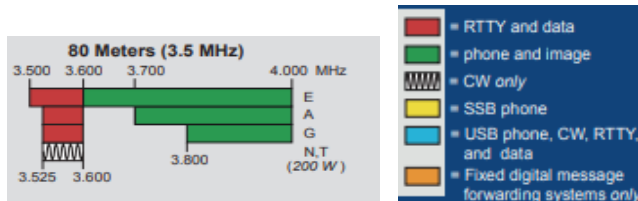

G1A07 [97.301(d)]

Which of the following frequencies is within the General class portion of the 20-meter phone band?

14305 kHz

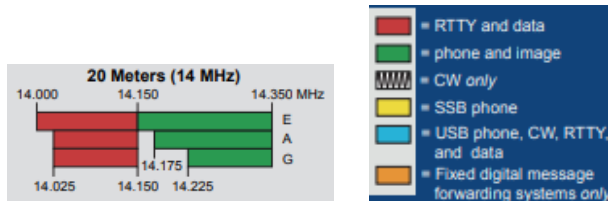

G1A08 [97.301(d)]

Which of the following frequencies is within the General class portion of the 80-meter band?

3560 kHz

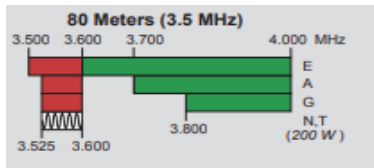

3560 is in the RTTY portion of the band (red area)

G1A09 [97.301(d)]

Which of the following frequencies is within the General class portion of the 15-meter band?

21300 kHz

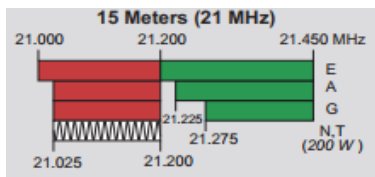

G1A10 [97.301(d)]

Which of the following frequencies is available to a control operator holding a General class license?

A. 28.020 MHz

B. 28.350 MHz

C. 28.550 MHz

D. All these choices are correct

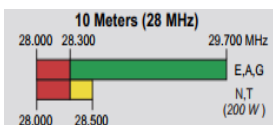

G1A11 [97.301]

When General class licensees are not permitted to use the entire voice portion of a band, which portion of the voice segment is generally available to them? **The upper frequency end**

G1A12 [97.303]

Which of the following applies when the FCC rules designate the Amateur Service as a secondary user on a band? **Amateur stations can use the band only if they do not cause harmful interference to primary users**

G1A13 [97.303(5)(h)(2)(j)]

What is the appropriate action if, when operating on either the 30-meter or 60-meter bands, a station in the primary service interferes with your contact? **Move to a clear frequency or stop transmitting**

G1A14 [97.301(d)]

Which of the following may apply in areas under FCC jurisdiction outside of ITU Region 2?

Frequency allocations may differ

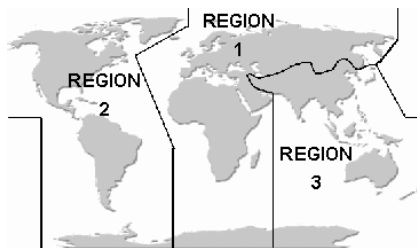

ITU – International Telecommunications Union is divided into three regions, the US is in region 2

G1A15 [97.205(b)]

What portion of the 10-meter band is available for repeater use? **The portion above 29.5 MHz**

Note: this is not shown on the ARRL band plan

G1B – Antenna structure limitations; good engineering and good amateur practice; beacon operation; prohibited transmissions; retransmitting radio signals

G1B01 [97.15(a)]

What is the maximum height above ground to which an antenna structure may be erected without requiring notification to the FAA and registration with the FCC, provided it is not at or near a public use airport?

200 feet

G1B02 [97.203(b)]

With which of the following conditions must beacon stations comply? **There must be no more than one beacon signal transmitting in the same band from the same station location**

G1B03 [97.3(a)(9)]

Which of the following is a purpose of a beacon station as identified in the FCC rules? **Observation of propagation and reception**

G1B04 [97.113(c)]

Which of the following transmissions is permitted? **Occasional retransmission of weather and propagation forecast information from U.S. government stations**

G1B05 [97.111(5)(b)]

Which of the following one-way transmissions are permitted? **Transmissions necessary to assist learning the International Morse code**

A	· - -	N	- - ·	1	- - - - -	ITU Recommended Prosigns	
B	- - - ·	O	- - - -	2	- - - - -	Wait	· - - ·
C	- - - -	P	- - - ·	3	- - - ·	Error	- - - - -
D	- - ·	Q	- - - -	4	- - - ·	Understood	- - - - -
E	·	R	- · -	5	- - - ·	Invitation to transmit	- - -
F	- - - ·	S	- - ·	6	- - - ·	End of work	- - - - -
G	- - ·	T	-	7	- - - ·	Starting signal	- - - - -
H	- - - ·	U	- - ·	8	- - - -	ITU Non-English Extensions	
I	· ·	V	- - - ·	9	- - - -	à	- - - -
J	- - - -	W	- - - ·	0	- - - -	á	- - - -
K	- - - -	X	- - - ·	.	- - - -	è	- - - -
L	- - - ·	Y	- - - -	,	- - - -	é	- - - -
M	- - -	Z	- - - ·	@	- - - -	ç	- - - -

International Morse Code
with ITU Extensions
CREATED BY: Sam C. Chan
BRAVO TECHNOLOGY CENTER

G1B06 [97.15(b), PRB-1, 101 FCC 2d 952 (1985)]

Under what conditions are state and local governments permitted to regulate Amateur Radio antenna structures?

Amateur Service communications must be reasonably accommodated, and regulations must constitute the minimum practical to accommodate a legitimate purpose of the state or local entity

G1B07 [97.113(a)(4)]

What are the restrictions on the use of abbreviations or procedural signals in the Amateur Service?

They may be used if they do not obscure the meaning of a message

G1B08 [97.101(a)]

When choosing a transmitting frequency, what should you do to comply with good amateur practice?

- A. Ensure that the frequency and mode selected are within your license class privileges**
- B. Follow generally accepted band plans agreed to by the Amateur Radio community**
- C. Monitor the frequency before transmitting**
- D. All these choices are correct**

G1B09 [97.203(d)]

On what HF frequencies are automatically controlled beacons permitted?

28.20 MHz to 28.30 MHz

An amateur radio propagation beacon is a radio beacon, whose purpose is the investigation of the propagation of radio signals. Most radio propagation beacons use amateur radio frequencies. They can be found on LF, MF, HF, VHF, UHF, and microwave frequencies.

Got to <https://www.ncdxf.org/beacon/> for more information and frequencies for beacon stations.

G1B10 [97.203(c)]

What is the power limit for beacon stations? **100 watts PEP output**

G1B11 [97.101(a)]

Who or what determines “good engineering and good amateur practice,” as applied to the operation of an amateur station in all respects not covered by the Part 97 rules? **The FCC**

G1B12 [97.111(a)(1)]

When is it permissible to communicate with amateur stations in countries outside the areas administered by the Federal Communications Commission? **When the contact is with amateurs in any country except those whose administrations have notified the ITU that they object to such communications**

Only Yemen and North Korea currently do not allow ham radio by its citizens

G1C – Transmitter power regulations; data emission standards; 60-meter operation requirements

G1C01 [97.313(c)(1)]

What is the maximum transmitting power an amateur station may use on 10.140 MHz? **200 watts PEP output**

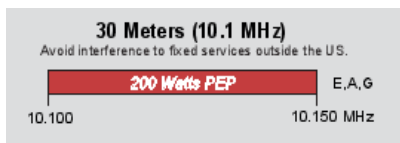

PEP, Peak envelope power is the peak power of the voice (or other Modulation type). Single sideband power is a function of the modulation signal. The louder you talk the more peak power your transmission has (up to the limit of your transmitter)

G1C02 [97.313]

What is the maximum transmitting power an amateur station may use on the 12-meter band? **1500 watts PEP output**

G1C03 (A) [97.303(h)(1)]

What is the maximum bandwidth permitted by FCC rules for Amateur Radio stations transmitting on USB frequencies in the 60-meter band? **2.8 kHz**

G1C04 [97.313(a)]

Which of the following limitations apply to transmitter power on every amateur band?

Only the minimum power necessary to carry out the desired communications should be used

G1C05 [97.313]

What is the limit for transmitter power on the 28 MHz band for a General Class control operator?

1500 watts PEP output

G1C06 [97.313]

What is the limit for transmitter power on the 1.8 MHz band? **1500 watts PEP output**

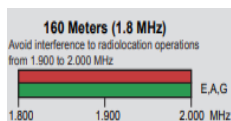

G1C07 [97.305(c), 97.307(f)(3)]

What is the maximum symbol rate permitted for RTTY or data emission transmission on the 20-meter band?

300 baud

Maximum Symbol rates (baud)

<u>Band</u>	<u>Max Symbol Rate</u>	<u>Signal Bandwidth</u>
<i>Below 10 Meters</i>	<i>300 baud</i>	<i>1 KHz</i>
<i>10 Meters</i>	<i>1200 baud</i>	<i>1 KHz</i>
<i>6 & 2 meters</i>	<i>19.6 K baud</i>	<i>20 KHz</i>
<i>1.25m to 70 cm</i>	<i>56 K baud</i>	<i>100 KHz</i>
<i>23 cm and above</i>	<i>no limit</i>	<i>no limit</i>

Bit Rate vs. Baud Rate

- bit: a unit of information
- baud: a unit of signaling speed
- Bit rate (or data rate): b
 - Number of bits transmitted per second
- Baud rate (or symbol rate): s
 - number of symbols transmitted per second

G1C08 [97.307(f)(3)]

What is the maximum symbol rate permitted for RTTY or data emission transmitted at frequencies below 28 MHz? **300 baud**

See answer in G1C07

G1C09 [97.305(c) and 97.307(f)(5)]

What is the maximum symbol rate permitted for RTTY or data emission transmitted on the 1.25-meter and 70-centimeter bands? **56 kilobaud**

See answer in G1C07

G1C10 [97.305(c) and 97.307(f)(4)]

What is the maximum symbol rate permitted for RTTY or data emission transmissions on the 10-meter band?
1200 baud

See answer in G1C07

G1C11 [97.305(c) and 97.307(f)(5)]

What is the maximum symbol rate permitted for RTTY or data emission transmissions on the 2-meter band?
19.6 kilobaud

See answer in G1C07

G1C12 [97.303(i)]

Which of the following is required by the FCC rules when operating in the 60-meter band?
If you are using an antenna other than a dipole, you must keep a record of the gain of your antenna

G1C13 [97.309(a)(4)]

What must be done before using a new digital protocol on the air? **Publicly document the technical characteristics of the protocol**

G1C14 [97.313(i)]

What is the maximum power limit on the 60-meter band? **ERP of 100 watts PEP with respect to a dipole**

Effective radiated power is the sum of the transmitter output power and any gain or loss in the path to the antenna. A 200-watt transmitter with 3 dB of cable loss would be an ERP of 100 watts into the antenna.

G1C15 (D) [97.313]

What measurement is specified by FCC rules that regulate maximum power output? **PEP**

G1D – Volunteer Examiners and Volunteer Examiner Coordinators; temporary identification; element credit

G1D01 [97.501, 97.505(a)]

Who may receive partial credit for the elements represented by an expired Amateur Radio license?
Any person who can demonstrate that they once held an FCC-issued General, Advanced, or Amateur Extra class license that was not revoked by the FCC

G1D02 [97.509(b)(3)(i)]

What license examinations may you administer when you are an accredited VE holding a General class operator license? **Technician only**

G1D03 [97.9(b)]

On which of the following band segments may you operate if you are a Technician class operator and have a Certificate of Successful Completion of Examination (CSCE) for General class privileges?
On any General or Technician class band segment

G1D04 [97.509(3)(i)(c)]

Which of the following is a requirement for administering a Technician class license examination?
At least three General class or higher VEs must observe the examination

G1D05 [97.509(b)(3)(i)]

Which of the following must a person have before they can be an administering VE for a Technician class license examination? **An FCC General class or higher license and VEC accreditation**

G1D06 [97.119(f)(2)]

When must you add the special identifier "AG" after your call sign if you are a Technician class licensee and have a Certificate of Successful Completion of Examination (CSCE) for General class operator privileges, but the FCC has not yet posted your upgrade on its website? **Whenever you operate using General class frequency privileges**

As soon as your license appears on the FCC ULS Data base you do not need to use AG identifier

G1D07 [97.509(b)(1)]

Volunteer Examiners are accredited by what organization? **A Volunteer Examiner Coordinator**

G1D08 [97.509(b)(3)]

Which of the following criteria must be met for a non-U.S. citizen to be an accredited Volunteer Examiner? **The person must hold an FCC granted Amateur Radio license of General class or above**

G1D09 [97.9(b)]

How long is a Certificate of Successful Completion of Examination (CSCE) valid for exam element credit? **365 days**

G1D10 [97.509(b)(2)]

What is the minimum age that one must be to qualify as an accredited Volunteer Examiner? **18 years**

G1D11 [97.505]

What is required to obtain a new General class license after a previously-held license has expired and the two year grace period has passed? **The applicant must pass the current Element 2 exam**

Element 2 is the Technician License Exam

G1E – Control categories; repeater regulations; third-party rules; ITU regions; automatically controlled digital station

G1E01 [97.115(b)(2)]

Which of the following would disqualify a third party from participating in stating a message over an amateur station? **The third party's amateur license has been revoked and not reinstated**

G1E02 [97.205(b)]

When may a 10-meter repeater retransmit the 2-meter signal from a station that has a Technician class control operator? **Only if the 10-meter repeater control operator holds at least a General class license**

G1E03 [97.221]

What is required to conduct communications with a digital station operating under automatic control outside the automatic control band segments? **The station initiating the contact must be under local or remote control**

G1E04 [97.13(b), 97.303, 97.311(b)]

Which of the following conditions require a licensed Amateur Radio operator to take specific steps to avoid harmful interference to other users or facilities?

- A. When operating within one mile of an FCC Monitoring Station
- B. When using a band where the Amateur Service is secondary
- C. When a station is transmitting spread spectrum emissions
- D. All these choices are correct

G1E05 [97.115(a)(2),97.117]

What types of messages for a third party in another country may be transmitted by an amateur station?

Only messages relating to Amateur Radio or remarks of a personal character, or messages relating to emergencies or disaster relief

G1E06 [97.301, ITU Radio Regulations]

The frequency allocations of which ITU region apply to radio amateurs operating in North and South America?

Region 2

See answer for G1A14

G1E07 [97.111]

In what part of the 13-centimeter band may an amateur station communicate with non-licensed Wi-Fi stations?

No part

13 cm is the commercial wi-fi band around 2300 MHz

G1E08 (B) [97.313(j)]

What is the maximum PEP output allowed for spread spectrum transmissions? **10 watts**

G1E09 [97.115]

Under what circumstances are messages that are sent via digital modes exempt from Part 97 third-party rules that apply to other modes of communication? **Under no circumstances**

G1E10 [97.101]

Why should an amateur operator normally avoid transmitting on 14.100, 18.110, 21.150, 24.930 and 28.200 MHz? **A system of propagation beacon stations operates on those frequencies**

G1E11 (D) [97.221, 97.305]

On what bands may automatically controlled stations transmitting RTTY or data emissions communicate with other automatically controlled digital stations? **Anywhere in the 6-meter or shorter wavelength bands, and in limited segments of some of the HF bands**

SUBELEMENT G2 – OPERATING PROCEDURES

[5 Exam Questions – 5 Groups]

G2A – Phone operating procedures; USB/LSB conventions; breaking into a contact; VOX operation

G2A01

Which sideband is most commonly used for voice communications on frequencies of 14 MHz or higher?

Upper sideband

Generally, we use upper sideband for all frequencies above 10 MHz and lower sideband for all frequencies below 10 MHz

G2A02

Which of the following modes is most commonly used for voice communications on the 160-meter, 75-meter, and 40-meter bands? **Lower sideband**

These frequencies are all below 10 MHz, therefore LSB

G2A03

Which of the following is most commonly used for SSB voice communications in the VHF and UHF bands?

Upper sideband

These frequencies are all above 10 MHz, therefore USB

G2A04

Which mode is most commonly used for voice communications on the 17-meter and 12-meter bands?

Upper sideband

These frequencies are all above 10 MHz, therefore USB

G2A05

Which mode of voice communication is most commonly used on the HF amateur bands? **Single sideband**

G2A06

Which of the following is an advantage when using single sideband, as compared to other analog voice modes on the HF amateur bands? **Less bandwidth used and greater power efficiency**

SSB is an AM signal where the carrier is removed (suppressed) and only one of the side bands is transmitted

G2A07

Which of the following statements is true of the single sideband voice mode?

Only one sideband is transmitted; the other sideband and carrier are suppressed

G2A08

What is the recommended way to break in to a phone contact? **Say your call sign once**

G2A09

Why do most amateur stations use lower sideband on the 160-meter, 75-meter, and 40-meter bands?

It is good amateur practice

These frequencies are all below generally agreed on rule that below 10 MHz use LSB

G2A10

Which of the following statements is true of voice VOX operation versus PTT operation?

It allows “hands free” operation

VOX stands for Voice Operated Transmit. Whenever your voice is sensed the radio goes into transmit mode

G2A11

Generally, who should respond to a station in the contiguous 48 states who calls “CQ DX”?

Any stations outside the lower 48 states

G2A12

What control is typically adjusted for proper ALC setting on an amateur single sideband transceiver?

Transmit audio or microphone gain

G2B – Operating courtesy; band plans; emergencies, including drills and emergency communications

G2B01

Which of the following is true concerning access to frequencies?

Except during emergencies, no amateur station has priority access to any frequency

G2B02

What is the first thing you should do if you are communicating with another amateur station and hear a station in distress break in? **Acknowledge the station in distress and determine what assistance may be needed**

G2B03

What is good amateur practice if propagation changes during a contact and you notice interference from other stations on the frequency? **Attempt to resolve the interference problem with the other stations in a mutually acceptable manner**

G2B04

When selecting a CW transmitting frequency, what minimum separation should be used to minimize interference to stations on adjacent frequencies? **150 to 500 Hz**

G2B05

When selecting an SSB transmitting frequency, what minimum separation should be used to minimize interference to stations on adjacent frequencies? **Approximately 3 kHz**

G2B06

What is a practical way to avoid harmful interference on an apparently clear frequency before calling CQ on CW or phone? **Send “QRL?” on CW, followed by your call sign; or, if using phone, ask if the frequency is in use, followed by your call sign**

QRL is the Q signal for “Are you busy?” or “Is this frequency in use?”

G2B07

Which of the following complies with good amateur practice when choosing a frequency on which to initiate a call? **Follow the voluntary band plan for the operating mode you intend to use**

This would be the ARRL Band Plan at the beginning of this Syllabus

G2B08

What is the voluntary band plan restriction for U.S. stations transmitting within the 48 contiguous states in the 50.1 to 50.125 MHz band segment? **Only contacts with stations not within the 48 contiguous states**

This is not shown on the ARRL Band Plan

G2B09 [97.407(a)]

Who may be the control operator of an amateur station transmitting in RACES to assist relief operations during a disaster? **Only a person holding an FCC-issued amateur operator license**

G2B10 [97.405(b)]

When is an amateur station allowed to use any means at its disposal to assist another station in distress? **At any time during an actual emergency**

G2B11 [97.405]

What frequency should be used to send a distress call? **Whichever frequency has the best chance of communicating the distress message**

G2C – CW operating procedures and procedural signals; Q signals and common abbreviations: full break-in**G2C01**

Which of the following describes full break-in telegraphy (QSK)? **Transmitting stations can receive between code characters and elements**

G2C02

What should you do if a CW station sends “QRS?” **Send slower**

G2C03

What does it mean when a CW operator sends “KN” at the end of a transmission? **Listening only for a specific station or stations**

G2C04

What does the Q signal “QRL?” mean? **“Are you busy?” or “Is this frequency in use?”**

G2C05

What is the best speed to use when answering a CQ in Morse code? **The fastest speed at which you are comfortable copying, but no faster than the CQ**

G2C06

What does the term “zero beat” mean in CW operation? **Matching the transmit frequency to the frequency of a received signal**

G2C07

When sending CW, what does a “C” mean when added to the RST report? **Chirpy or unstable signal**

G2C08

What prosign is sent to indicate the end of a formal message when using CW? **AR**

G2C09

What does the Q signal “QSL” mean? **I acknowledge receipt**

G2C10

What does the Q signal “QRN” mean? **I am troubled by static**

G2C11

What does the Q signal “QRV” mean? **I am ready to receive messages**

G2D – Volunteer Monitoring Program; HF operations

G2D01

What is the Volunteer Monitoring Program? **Amateur volunteers who are formally enlisted to monitor the airwaves for rules violations**

Volunteer Monitors are accredited by the ARRL Volunteer Monitoring Program Administrator. These monitoring stations had been previously designated Official Observer Stations.

G2D02

Which of the following are objectives of the Volunteer Monitoring Program? **To encourage amateur radio operators to self-regulate and comply with the rules**

G2D03

What skills learned during hidden transmitter hunts are of help to the Volunteer Monitoring Program? **Direction finding used to locate stations violating FCC rules**

G2D04

Which of the following describes an azimuthal projection map? **A map that shows true bearings and distances from a particular location**

The azimuthal equidistant projection is an azimuthal map that has the useful properties that all points on the map are at proportionally correct distances ...

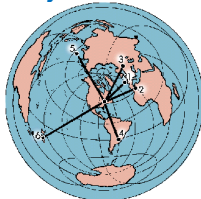

G2D05

Which of the following is a good way to indicate on a clear frequency in the HF phone bands that you are looking for a contact with any station? **Repeat “CQ” a few times, followed by “this is,” then your call sign a few times, then pause to listen, repeat as necessary**

G2D06

How is a directional antenna pointed when making a “long-path” contact with another station?

180 degrees from the station’s short-path heading



G2D07

Which of the following are examples of the NATO Phonetic Alphabet? **Alpha, Bravo, Charlie, Delta**

Official NATO Military Alphabet

Character	Alphabet	Pronunciation	Character	Alphabet	Pronunciation
A	Alpha	Al fah	N	November	No yem ber
B	Bravo	Brah voh	O	Oscar	Ogss cah
C	Charlie	Char lee	P	Papa	Ppah pah
D	Delta	Dell tah	Q	Quebec	Qkeh beck
E	Echo	Eck oh	R	Romeo	Rqew me oh
F	Foxtrot	Foks trot	S	Sierra	Ssee alf rah
G	Golf	Golf	T	Tango	Ttang go
H	Hotel	Hoh tell	U	Uniform	Uyou nee form
I	India	In dee ah	V	Victor	Vvik tah
J	Juliet	Jew lee ett	W	Whiskey	Wwisa key
K	Kilo	Key loh	X	X-Ray	Xecks ray
L	Lima	Lee mah	Y	Yankee	Yyang key
M	Mike	Mike	Z	Zulu	Zzoo loo

G2D08

What is a reason why many amateurs keep a station log? **To help with a reply if the FCC requests information**

G2D09

Which of the following is required when participating in a contest on HF frequencies?

Identify your station per normal FCC regulations

G2D10

What is QRP operation? **Low-power transmit operation**

QRP is both a popular technical and operating challenge. Low power transmitters and transceivers (typically 5 watts) are widely popular construction projects. With power efficient modes like CW and PSK31, a skilled operator can work the globe!

G2D11

Which of the following is typical of the lower HF frequencies during the summer?

High levels of atmospheric noise or “static”

G2E – Digital operating procedures

G2E01

Which mode is normally used when sending RTTY signals via AFSK with an SSB transmitter? **LSB**

RTTY is Radio Teletype – AFSK is Audio Frequency Shift Keying, SSB is Single Sideband, LSB is lower sideband

G2E02

How can a PACTOR modem or controller be used to determine if the channel is in use by other PACTOR stations? **Put the modem or controller in a mode which allows monitoring communications without a connection**

G2E03

What symptoms may result from other signals interfering with a PACTOR or WINMOR transmission?

- A. Frequent retries or timeouts**
- B. Long pauses in message transmission**
- C. Failure to establish a connection between stations**
- D. All these choices are correct**

G2E04

What segment of the 20-meter band is most often used for digital transmissions (avoiding the DX propagation beacons)? **14.070 - 14.112 MHz**

G2E05

What is the standard sideband used to generate a JT65, JT9, or FT8 digital signal when using AFSK in any amateur band? **USB**

This does not follow the normal upper or Lower SSB rule

G2E06

What is the most common frequency shift for RTTY emissions in the amateur HF bands?

170 Hz

G2E07

What segment of the 80-meter band is most commonly used for digital transmissions? **3570 – 3600 kHz**

G2E08

In what segment of the 20-meter band are most PSK31 operations commonly found?

Below the RTTY segment, near 14.070 MHz

G2E09

How do you join a contact between two stations using the PACTOR protocol?

Joining an existing contact is not possible, PACTOR connections are limited to two stations

G2E10

Which of the following is a way to establish contact with a digital messaging system gateway station?

Transmit a connect message on the station's published frequency

G2E11

Which of the following is characteristic of the FT8 mode of the WSJT-X family?

Typical exchanges are limited to call signs, grid locators, and signal reports

G2E12

Which of the following connectors would be a good choice for a serial data port?

DE-9

Sometimes referred to as a DB-9 connector



G2E13

Which communication system sometimes uses the internet to transfer messages? **Winlink**

Winlink, also known as the Winlink 2000 Network, is a worldwide radio messaging system that uses amateur-band radio frequencies as well as government and commercial marine frequencies ^[1] to provide radio interconnection services that include email with attachments, position reporting, weather bulletins, emergency relief communications, and message relay

G2E14

What could be wrong if you cannot decode an RTTY or other FSK signal even though it is apparently tuned in properly?

- A. The mark and space frequencies may be reversed**
- B. You may have selected the wrong baud rate**
- C. You may be listening on the wrong sideband**
- D. All these choices are correct**

G2E15

Which of the following is a requirement when using the FT8 digital mode?

Computer time accurate within approximately 1 second

SUBELEMENT G3 – RADIO WAVE PROPAGATION [3 Exam Questions – 3 Groups]

G3A – Sunspots and solar radiation; ionospheric disturbances; propagation forecasting and indices

G3A01

What is the significance of the sunspot number with regard to HF propagation? **Higher sunspot numbers generally indicate a greater probability of good propagation at higher frequencies**

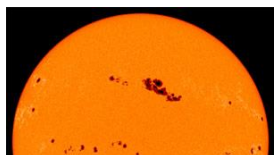

G3A02

What effect does a Sudden Ionospheric Disturbance have on the daytime ionospheric propagation of HF radio waves? **It disrupts signals on lower frequencies more than those on higher frequencies**

A sudden ionospheric disturbance (SID) is an abnormally high ionization/plasma density in the D region of the ionosphere caused by a solar flare and/or solar particle event (SPE).

G3A03

Approximately how long does it take the increased ultraviolet and X-ray radiation from solar flares to affect radio propagation on Earth? **8 minutes**

G3A04

Which of the following are least reliable for long-distance communications during periods of low solar activity? **15 meters, 12 meters, and 10 meters**

G3A05

What is the solar flux index? **A measure of solar radiation at 10.7 centimeters wavelength**
10.7 cm is approx. 28,00 MHz or 2.8 GHz

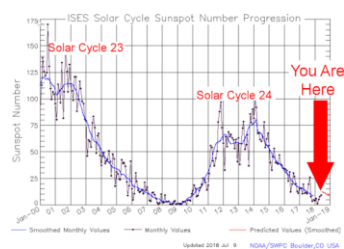
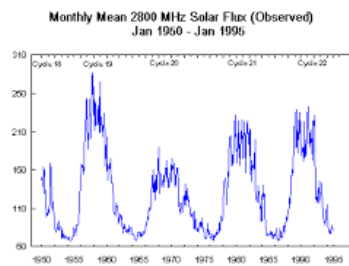

G3A06

What is a geomagnetic storm? **A temporary disturbance in Earth's magnetosphere**

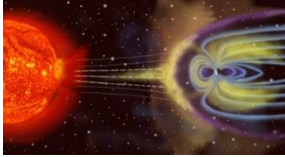

G3A07

At what point in the solar cycle does the 20-meter band usually support worldwide propagation during daylight hours? **At any point in the solar cycle**

G3A08

Which of the following effects can a geomagnetic storm have on radio propagation?

Degraded high-latitude HF propagation

G3A09

What benefit can high geomagnetic activity have on radio communications? **Auroras that can reflect VHF signals**



G3A10

What causes HF propagation conditions to vary periodically in a roughly 28-day cycle?

The sun's rotation on its axis

G3A11

How long does it take charged particles from coronal mass ejections to affect radio propagation on Earth?

20 to 40 hours

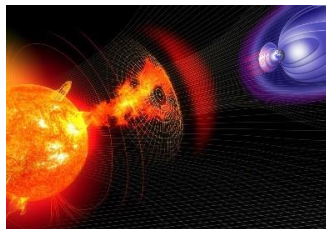

G3A12

What does the K-index indicate? **The short-term stability of Earth's magnetic field**

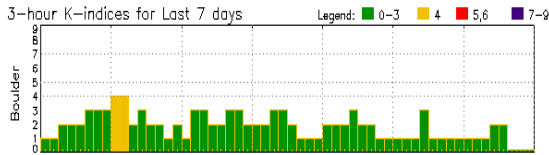

G3A13

What does the A-index indicate? **The long-term stability of Earth's geomagnetic field**

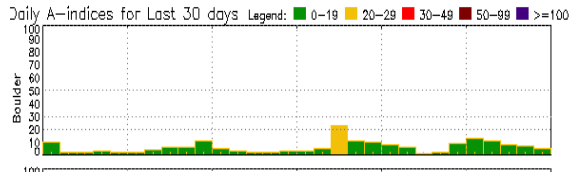

G3A14

How are radio communications usually affected by the charged particles that reach Earth from solar coronal holes? **HF communications are disturbed**

A coronal hole is a large region in the corona which is less dense and is cooler than its surrounds. Such holes may appear at any time of the solar cycle but they are most common during the declining phase of the cycle. Coronal holes occur when the Sun's magnetic field is open to interplanetary space.

G3B – Maximum Usable Frequency; Lowest Usable Frequency; propagation

G3B01

What is a characteristic of skywave signals arriving at your location by both short-path and long-path propagation? **Slightly delayed echo might be heard**

G3B02

What factors affect the MUF?

- A. Path distance and location
- B. Time of day and season
- C. Solar radiation and ionospheric disturbances
- D. All these choices are correct

MUF is the Maximum Useable Frequency

G3B03

Which of the following applies when selecting a frequency for lowest attenuation when transmitting on HF? **Select a frequency just below the MUF**

G3B04

What is a reliable way to determine if the MUF is high enough to support skip propagation between your station and a distant location on frequencies between 14 and 30 MHz? **Listen for signals from an international beacon in the frequency range you plan to use**

G3B05

What usually happens to radio waves with frequencies below the MUF and above the LUF when they are sent into the ionosphere? **They are bent back to Earth**
LUF is the Lowest Useable Frequency

G3B06

What usually happens to radio waves with frequencies below the LUF? **They are completely absorbed by the ionosphere**

G3B07

What does LUF stand for? **The Lowest Usable Frequency for communications between two points**

G3B08

What does MUF stand for? **The Maximum Usable Frequency for communications between two points**

G3B09

What is the approximate maximum distance along the Earth's surface that is normally covered in one hop using the F2 region? **2,500 miles**

G3B10

What is the approximate maximum distance along the Earth's surface that is normally covered in one hop using the E region? **1,200 miles**

G3B11

What happens to HF propagation when the LUF exceeds the MUF? **No HF radio frequency will support ordinary skywave communications over the path**

G3C – Ionospheric layers; critical angle and frequency; HF scatter; Near Vertical Incidence Skywave

G3C01

Which ionospheric layer is closest to the surface of Earth? **The D layer**

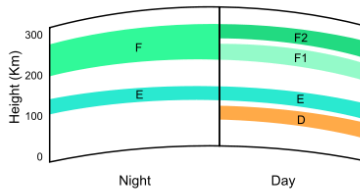

G3C02

Where on Earth do ionospheric layers reach their maximum height? **Where the sun is overhead**

G3C03

Why is the F2 region mainly responsible for the longest distance radio wave propagation?

Because it is the highest ionospheric region

G3C04

What does the term “critical angle” mean, as used in radio wave propagation?

The highest takeoff angle that will return a radio wave to Earth under specific ionospheric conditions

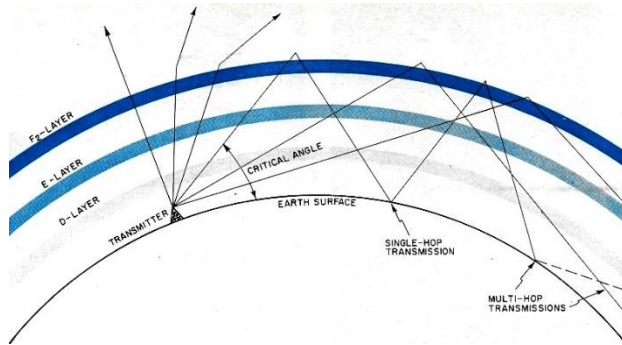

G3C05

Why is long-distance communication on the 40-meter, 60-meter, 80-meter, and 160-meter bands more difficult during the day? **The D layer absorbs signals at these frequencies during daylight hours**

The D layer is not there after sunset (see graphic in G3C01)

G3C06

What is a characteristic of HF scatter? **Signals have a fluttering sound**

Signals that are scattered in the ionosphere take different paths to the receiving station

G3C07

What makes HF scatter signals often sound distorted? **Energy is scattered into the skip zone through several different radio wave paths**

G3C08

Why are HF scatter signals in the skip zone usually weak? **Only a small part of the signal energy is scattered into the skip zone**

G3C09

What type of propagation allows signals to be heard in the transmitting station's skip zone? **Scatter**

G3C10

What is Near Vertical Incidence Skywave (NVIS) propagation? **Short distance MF or HF propagation using high elevation angles**

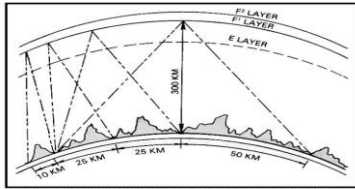

Figure M-1. Near-vertical incidence sky-wave propagation concept.

G3C11

Which ionospheric layer is the most absorptive of long skip signals during daylight hours on frequencies below 10 MHz? **The D layer**

SUBELEMENT G4 – AMATEUR RADIO PRACTICES

[5 Exam Questions – 5 groups]

G4A – Station operation and setup

G4A01

What is the purpose of the “notch filter” found on many HF transceivers? **To reduce interference from carriers in the receiver passband**

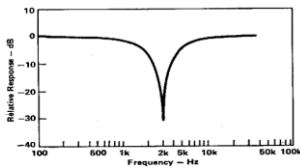

G4A02

What is one advantage of selecting the opposite, or “reverse,” sideband when receiving CW signals on a typical HF transceiver? **It may be possible to reduce or eliminate interference from other signals**

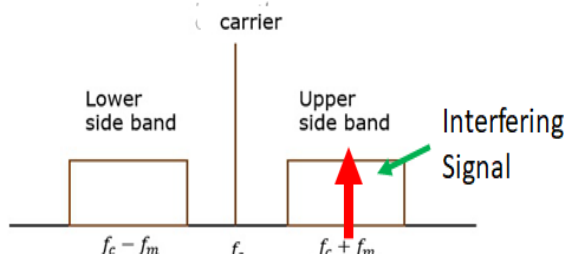

G4A03

What is normally meant by operating a transceiver in “split” mode? **The transceiver is set to different transmit and receive frequencies**

G4A04 (B)

What reading on the plate current meter of a vacuum tube RF power amplifier indicates correct adjustment of the plate tuning control? **A pronounced dip**

When the plate tuning reaches resonance, the plate current will dip. This is because energy is moving back and forth between the capacitor and the inductor

G4A05

What is a reason to use Automatic Level Control (ALC) with an RF power amplifier?

To reduce distortion due to excessive drive

G4A06

What type of device is often used to match transmitter output impedance to an impedance not equal to 50 ohms?

Antenna coupler or antenna tuner

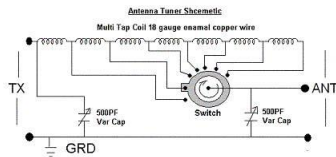

G4A07

What condition can lead to permanent damage to a solid-state RF power amplifier? **Excessive drive power**

G4A08

What is the correct adjustment for the load or coupling control of a vacuum tube RF power amplifier?

Maximum power output without exceeding maximum allowable plate current

G4A09

Why is a time delay sometimes included in a transmitter keying circuit? **To allow time for transmit-receive changeover operations to complete properly before RF output is allowed**

G4A10

What is the purpose of an electronic keyer? **Automatic generation of strings of dots and dashes for CW operation**

G4A11

Which of the following is a use for the IF shift control on a receiver? **To avoid interference from stations very close to the receive frequency**

G4A12

Which of the following is a common use for the dual-VFO feature on a transceiver?

To permit monitoring of two different frequencies

G4A13

What is one reason to use the attenuator function that is present on many HF transceivers?

To reduce signal overload due to strong incoming signals

G4A14

What is likely to happen if a transceiver's ALC system is not set properly when transmitting AFSK signals with the radio using single sideband mode? **Improper action of ALC distorts the signal and can cause spurious emissions**

G4A15

Which of the following can be a symptom of transmitted RF being picked up by an audio cable carrying AFSK data signals between a computer and a transceiver?

A. The VOX circuit does not un-key the transmitter

B. The transmitter signal is distorted

C. Frequent connection timeouts

D. All these choices are correct

G4A16

How does a noise blanker work? **By reducing receiver gain during a noise pulse**

Typically, this is a network in the intermediate frequency section (IF) of the receiver; when a pulse of noise passes through the IF amplifiers, it is usually of greater amplitude than the desired signal. The noise blanker circuit momentarily reduces the gain of the IF stage during the impulse.

G4A17

What happens as the noise reduction control level in a receiver is increased?

Received signals may become distorted

G4B – Test and monitoring equipment; two-tone test

G4B01

What item of test equipment contains horizontal and vertical channel amplifiers? **An oscilloscope**



G4B02

Which of the following is an advantage of an oscilloscope versus a digital voltmeter?

Complex waveforms can be measured

G4B03

Which of the following is the best instrument to use when checking the keying waveform of a CW transmitter?

An oscilloscope

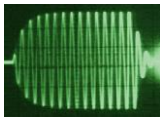

G4B04

What signal source is connected to the vertical input of an oscilloscope when checking the RF envelope pattern of a transmitted signal? **The attenuated RF output of the transmitter**

Be sure the attenuated signal is less than 100 mV, a direct connection will likely destroy the oscilloscope input circuitry

G4B05

Why is high input impedance desirable for a voltmeter? **It decreases the loading on circuits being measured**

G4B06

What is an advantage of a digital voltmeter as compared to an analog voltmeter? **Better precision for most uses**

G4B07

What signals are used to conduct a two-tone test? **Two non-harmonically related audio signals**

The method involves 2 audio tones simultaneously applied to the microphone input of the Transmitter. The two frequencies must not be harmonically related, and with both falling within the audio passband of the transmitter. 850 Hz and 2200 Hz are a good choice. the transmitter output is observed on an oscilloscope (not connected directly). With a spectrum analyzer having the appropriate resolution the third Order Intermodulation products (IM3) can also be observed.

G4B08

Which of the following instruments may be used to monitor relative RF output when making antenna and transmitter adjustments? **A field strength meter**

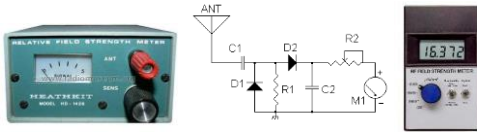

G4B09

Which of the following can be determined with a field strength meter? **The radiation pattern of an antenna**

G4B10

Which of the following can be determined with a directional wattmeter? **Standing wave ratio**

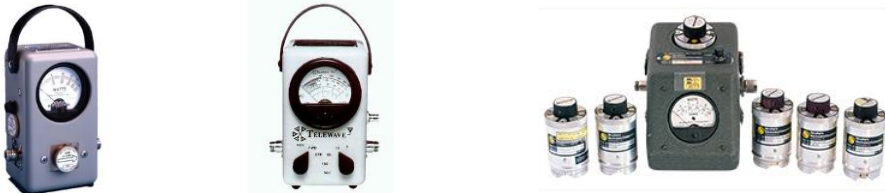

G4B11

Which of the following must be connected to an antenna analyzer when it is being used for SWR measurements? **Antenna and feed line**



G4B12

What problem can occur when making measurements on an antenna system with an antenna analyzer?

Strong signals from nearby transmitters can affect the accuracy of measurements

G4B13

What is a use for an antenna analyzer other than measuring the SWR of an antenna system?

Determining the impedance of coaxial cable

G4B14

What is an instance in which the use of an instrument with analog readout may be preferred over an instrument with digital readout? **When adjusting tuned circuits**

It is much easier to observe change with an analog volt meter than a digital meter when adjusting a transmitter output for a peak than a digital display.

G4B15

What type of transmitter performance does a two-tone test analyze? **Linearity**

G4C – Interference to consumer electronics; grounding; DSP**G4C01**

Which of the following might be useful in reducing RF interference to audio frequency devices?

Bypass capacitor

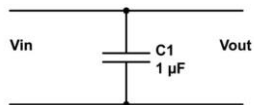

A properly selected capacitor across an audio or DC signal line will have an X_c in the audio range that will not affect the signal but any RF traveling on the audio line will be shunted (bypassed) by the lower X_c at RF Frequencies

G4C02

Which of the following could be a cause of interference covering a wide range of frequencies?

Arcing at a poor electrical connection

G4C03

What sound is heard from an audio device or telephone if there is interference from a nearby single sideband phone transmitter? **Distorted speech**

G4C04

What is the effect on an audio device when there is interference from a nearby CW transmitter?

On-and-off humming or clicking

G4C05

What might be the problem if you receive an RF burn when touching your equipment while transmitting on an HF band, assuming the equipment is connected to a ground rod?

The ground wire has high impedance on that frequency

G4C06

What effect can be caused by a resonant ground connection? **High RF voltages on the enclosures of station equipment**

G4C07

Why should soldered joints not be used with the wires that connect the base of a tower to a system of ground rods? **A soldered joint will likely be destroyed by the heat of a lightning strike**

Heat will be caused by the very high current flowing through the ground wire connection

G4C08

Which of the following would reduce RF interference caused by common-mode current on an audio cable?

Placing a ferrite choke around the cable



G4C09

How can a ground loop be avoided? **Connect all ground conductors to a single point**

G4C10

What could be a symptom of a ground loop somewhere in your station? **You receive reports of “hum” on your station’s transmitted signal**

G4C11

What technique helps to minimize RF “hot spots” in an amateur station? **Bonding all equipment enclosures together**

G4C12

Which of the following is an advantage of a receiver DSP IF filter as compared to an analog filter?

A wide range of filter bandwidths and shapes can be created

G4C13

Why must the metal enclosure of every item of station equipment be grounded?

It ensures that hazardous voltages cannot appear on the chassis

G4D – Speech processors; S meters; sideband operation near band edges

G4D01

What is the purpose of a speech processor as used in a modern transceiver?

Increase the intelligibility of transmitted phone signals during poor conditions

G4D02

Which of the following describes how a speech processor affects a transmitted single sideband phone signal?

It increases average power

The purpose of an RF speech processor is to increase the readability of your signal at the other end of a QSO. Speech processors do not increase peak power; they increase average power output. An up to 6 dB increase in average SSB power output.

G4D03

Which of the following can be the result of an incorrectly adjusted speech processor?

- A. Distorted speech
- B. Splatter
- C. Excessive background pickup
- D. All these choices are correct

G4D04

What does an S meter measure? **Received signal strength**

G4D05

How does a signal that reads 20 dB over S9 compare to one that reads S9 on a receiver, assuming a properly calibrated S meter? **It is 100 times more powerful**

10 dB is 10 times, 20 dB is another 10 times or 10 times 10 or 100 times

G4D06

Where is an S meter found? **In a receiver**

G4D07

How much must the power output of a transmitter be raised to change the S meter reading on a distant receiver from S8 to S9? **Approximately 4 times**

Signal Strength	Relative Intensity	Received Voltage
S1	-48 dB	0.2 μ V
S2	-42 dB	0.4 μ V
S3	-36 dB	0.8 μ V
S4	-30 dB	1.6 μ V
S5	-24 dB	3.2 μ V
S6	-18 dB	6.3 μ V
S7	-12 dB	13 μ V
S8	-6 dB	25 μ V
S9	0 dB	50 μ V

Every S-unit from 1 to 9 represents a 6-dB change, a 6-dB change is 4 times (Doubles every 3 dB)

G4D08

What frequency range is occupied by a 3 kHz LSB signal when the displayed carrier frequency is set to 7.178 MHz? **7.175 to 7.178 MHz**

The SSB signal will be up to 3 KHz below the dialed frequency or 7,178 KHz – 3 KHz or 7175 KHz or 7.175 MHz

G4D09

What frequency range is occupied by a 3 kHz USB signal with the displayed carrier frequency set to 14.347 MHz? **14.347 to 14.350 MHz**

The SSB signal will be up to 3 KHz above the dialed frequency or 14,347KHz + 3 KHz or 14,350 KHz or 14.350 MHz

G4D10

How close to the lower edge of the phone segment should your displayed carrier frequency be when using 3 kHz wide LSB? **At least 3 kHz above the edge of the segment**

G4D11

How close to the upper edge of the phone segment should your displayed carrier frequency be when using 3 kHz wide USB? **At least 3 kHz below the edge of the band**

G4E – HF mobile radio installations; alternative energy source operation

G4E01

What is the purpose of a capacitance hat on a mobile antenna? **To electrically lengthen a physically short antenna**

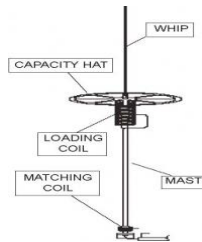

G4E02

What is the purpose of a corona ball on an HF mobile antenna? **To reduce RF voltage discharge from the tip of the antenna while transmitting**

The Impedance of an antenna increases as the distance from the feed point increases, Therefore the voltage along the antenna increases and at the end of the antenna the voltage is high and if the antenna is simply pointed at the end there will be static discharge into the atmosphere. The ball on the end spreads the charge to reduce static discharge.

G4E03

Which of the following direct, fused power connections would be the best for a 100 watt HF mobile installation? **To the battery using heavy-gauge wire**

G4E04

Why is it best NOT to draw the DC power for a 100-watt HF transceiver from a vehicle's auxiliary power socket? **The socket's wiring may be inadequate for the current drawn by the transceiver**

Most Auxiliary power sockets provide a maximum of 10 amperes and a 100-watt transceiver will draw 15 to 22 amperes.

G4E05

Which of the following most limits an HF mobile installation **Efficiency of the electrically short antenna**

You are not going to be able to put a full 1/4 wave antenna because of the longer wavelength for most HF frequencies. For these bands loading coils are usually inserted in the antenna.

G4E06

What is one disadvantage of using a shortened mobile antenna as opposed to a full-size antenna?

Operating bandwidth may be very limited

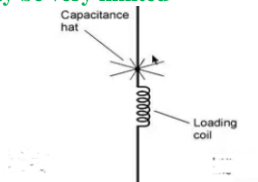

G4E07

Which of the following may cause receive interference in a radio installed in a vehicle?

- A. The battery charging system**
- B. The fuel delivery system**
- C. The vehicle control computer**
- D. All these choices are correct**

G4E08

What is the name of the process by which sunlight is changed directly into electricity?

Photovoltaic conversion

G4E09

What is the approximate open-circuit voltage from a fully illuminated silicon photovoltaic cell?

0.5 VDC

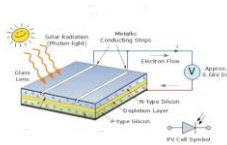

G4E10

What is the reason that a series diode is connected between a solar panel and a storage battery that is being charged by the panel? **The diode prevents self-discharge of the battery through the panel during times of low or no illumination**

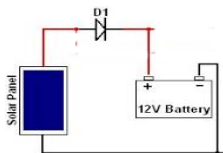

G4E11

Which of the following is a disadvantage of using wind as the primary source of power for an emergency station? **A large energy storage system is needed to supply power when the wind is not blowing**

SUBELEMENT G5 – ELECTRICAL PRINCIPLES
[3 Exam Questions – 3 Groups]

G5A – Reactance; inductance; capacitance; impedance; impedance matching

G5A01

What is impedance? **The opposition to the flow of current in an AC circuit**

G5A02

What is reactance? **Opposition to the flow of alternating current caused by capacitance or inductance**

G5A03

Which of the following causes opposition to the flow of alternating current in an inductor? **Reactance**

G5A04

Which of the following causes opposition to the flow of alternating current in a capacitor? **Reactance**

G5A05

How does an inductor react to AC? **As the frequency of the applied AC increases, the reactance increases**

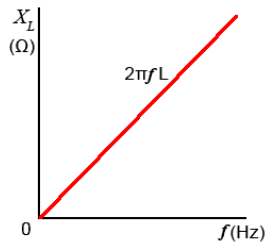

G5A06

How does a capacitor react to AC? **As the frequency of the applied AC increases, the reactance decreases**

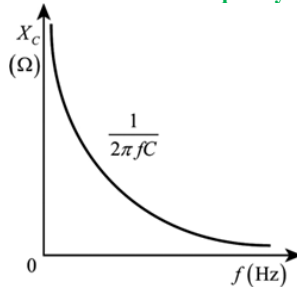

G5A07

What happens when the impedance of an electrical load is equal to the output impedance of a power source, assuming both impedances are resistive? **The source can deliver maximum power to the load**

G5A08

What is one reason to use an impedance matching transformer? **To maximize the transfer of power**

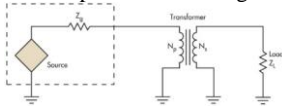

G5A09

What unit is used to measure reactance? **Ohm**

G5A10

Which of the following devices can be used for impedance matching at radio frequencies?

- A. A transformer
- B. A Pi-network
- C. A length of transmission line
- D. All these choices are correct

G5A11

Which of the following describes one method of impedance matching between two AC circuits?

Insert an LC network between the two circuits

G5B – The decibel; current and voltage dividers; electrical power calculations; sine wave root-mean-square (RMS) values; PEP calculations

G5B01

What dB change represents a factor of two increase or decrease in power? **Approximately 3 dB**

$$dB = 10(\log(\text{power ratio})) \text{ or } dB = 10(\log(2)) \text{ or } dB = 10(0.301) \text{ or } dB = 3.01$$

This Table will allow you to quickly solve many dB problems:

<i>minus (-)</i>	<i>dB</i>	<i>Plus (+)</i>
<i>one half</i>	<i>3</i>	<i>2 times</i>
<i>one Quarter</i>	<i>6</i>	<i>4 times</i>
<i>one tenth</i>	<i>10</i>	<i>10 times</i>

G5B02

How does the total current relate to the individual currents in each branch of a purely resistive parallel circuit?

It equals the sum of the currents through each branch

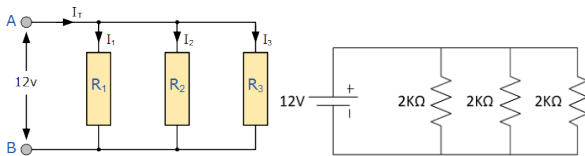

G5B03

How many watts of electrical power are used if 400 VDC is supplied to an 800 ohm load? **200 watts**

$$\text{Power} = (E)^2 / R \text{ or } P = (400)^2 / 800 \text{ or } 160,000 / 800 \text{ or } 200 \text{ Watts}$$

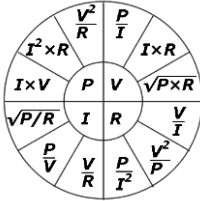
**G5B04**

How many watts of electrical power are used by a 12 VDC light bulb that draws 0.2 amperes? **2.4 watts**

$$\text{Power} = E \times I \text{ or } 12 \times 0.2 \text{ or } 2.4 \text{ watts}$$

G5B05

How many watts are dissipated when a current of 7.0 milliamperes flows through a 1250-ohm resistance?

Approximately 61 milliwatts

$$\text{Power} = (I)^2 \times R \text{ or } (0.007)^2 \times 1250 \text{ or } 0.00049 \times 1250 \text{ or } 0.6125 \text{ milliwatts or } 61.2 \text{ ma}$$

G5B06

What is the output PEP from a transmitter if an oscilloscope measures 200 volts peak-to-peak across a 50-ohm dummy load connected to the transmitter output? **100 watts**

Power = E² / R (Note E is in RMS volts so 200 V peak to peak must be divided by 2 to get the peak voltage then be multiplied by .707 to get the RMS then divided by 50 to get the power in watts)

$$\text{PEP} = ((.707(\text{Peak}))^2 / R \text{ or } ((.707(200/2)) / 50 \text{ or } 4,9984 / 50 \text{ or } 100 \text{ watts}$$

G5B07

What value of an AC signal produces the same power dissipation in a resistor as a DC voltage of the same value? **The RMS value**

RMS is an abbreviation for "Root Mean Square" Sometimes referred to as the DC equivalent voltage

G5B08

What is the peak-to-peak voltage of a sine wave with an RMS voltage of 120.0 volts? **339.4 volts**

$$\text{Peak to Peak} = 1.414(2(\text{RMS})) \text{ or } 1.414 (2(120)) \text{ or } 1.414 (240) \text{ or } 339.4 \text{ Volts}$$

G5B09

What is the RMS voltage of a sine wave with a value of 17 volts peak? **12 volts**

$$\text{RMS} = 0.707 (\text{peak}) \text{ or } 0.707 (17) \text{ or } 12.01 \text{ volts}$$

G5B10

What percentage of power loss would result from a transmission line loss of 1 dB? **20.6 percent**

dB percentage of input = $[10^{(dB \div 10)}] \times 100$ or $[10^{(-1/10)}] \times 100$ or 0.7943×100 or 79.43%
The loss would be the difference between the 100% and output percentage or $100\% - 79.43\%$ or 20.56%

G5B11

What is the ratio of peak envelope power to average power for an unmodulated carrier? **1.00**

Peak envelope power is the same as average power for an unmodulated carrier because the power is not changing with modulation.

G5B12

What would be the RMS voltage across a 50-ohm dummy load dissipating 1200 watts? **245 volts**

$$RMS = \sqrt{(P)(R)} \text{ or } \sqrt{(1200)(50)} \text{ or } \sqrt{60,000} \text{ or } 244.94 \text{ Volts}$$

G5B13

What is the output PEP of an unmodulated carrier if an average reading wattmeter connected to the transmitter output indicates 1060 watts? **1060 watts**

Peak envelope power is the same as average power for an unmodulated carrier because the power is not changing with modulation.

G5B14

What is the output PEP from a transmitter if an oscilloscope measures 500 volts peak-to-peak across a 50-ohm resistive load connected to the transmitter output? **625 watts**

$$PEP = (E)^2/R \text{ or } ((500/2) (.707))^2 / 50 \text{ or } ((250) (.707))^2 / 50 \text{ or } (176.75)^2 / 50 \text{ or } 312,240 / 50 \text{ or } 624.8 \text{ watts}$$

G5C – Resistors, capacitors, and inductors in series and parallel; transformers

G5C01 What causes a voltage to appear across the secondary winding of a transformer when an AC voltage source is connected across its primary winding? **Mutual inductance**

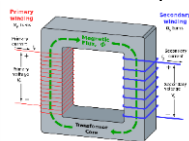
**G5C02**

What happens if a signal is applied to the secondary winding of a 4:1 voltage step-down transformer instead of the primary winding? **The output voltage is multiplied by 4**

A 100-turn primary with a 25-turn secondary is a 4:1 ratio. A 100-volt primary voltage would give a 25-volt secondary voltage.

G5C03

Which of the following components increases the total resistance of a resistor? **A series resistor**

Commented [JT2]:

G5C04

What is the total resistance of three 100-ohm resistors in parallel? **33.3 ohms**

The total resistance of equal value resistors is the value of one resistor divided by the number of resistors

$$R_t = 100 / 3 \text{ or } 33.3 \text{ ohms}$$

G5C05

If three equal value resistors in series produce 450 ohms, what is the value of each resistor? **150 ohms**

If the total resistance of three equal value resistors in series is 450 Ohms then one resistor is the total divided by 3 (the number of resistors in series). $R = R_t / N$ or $450 / 3$ or 150 ohms

G5C06

What is the RMS voltage across a 500-turn secondary winding in a transformer if the 2250-turn primary is connected to 120 VAC? **26.7 volts**

The secondary voltage is the ratio between the Primary and Secondary windings multiplied by the input voltage.

$$V = ((500) / (2250)) (120) \text{ or } (.2222) (120) \text{ or } 26.66 \text{ Volts}$$

G5C07

What is the turns ratio of a transformer used to match an audio amplifier having 600 ohm output impedance to a speaker having 4 ohm impedance? **12.2 to 1**

Turns ratio is the square root of the impedance ratio

$$\text{Turns ratio} = \sqrt{(600/4)} \text{ or } \sqrt{(150)} \text{ or } 12.24 \text{ to } 1$$

G5C08

What is the equivalent capacitance of two 5.0 nanofarad capacitors and one 750 picofarad capacitor connected in parallel? **10.750 nanofarads**

$$\text{Parallel Capacitors add therefore } C_t = 2(5) + 0.750 \text{ or } 10 + 0.750 \text{ or } 10.750 \text{ nF}$$

G5C09

What is the capacitance of three 100 microfarad capacitors connected in series? **33.3 microfarads**

Equal value series capacitors are the value of one capacitor divided by the number of capacitors

$$C_t = (100) / 3 \text{ or } 33.3 \text{ uF}$$

G5C10

What is the inductance of three 10 millihenry inductors connected in parallel? **3.3 millihenries**

Equal value parallel inductors are equal to the value of one inductor divided by the number of inductors

$$L_t = (10) / 3 \text{ or } 3.33 \text{ mH}$$

G5C11

What is the inductance of a 20 millihenry inductor connected in series with a 50 millihenry inductor?

70 millihenries

Series inductors add, therefore $L_t = 50 + 20$ or 70 mH

G5C12

What is the capacitance of a 20-microfarad capacitor connected in series with a 50 microfarad capacitor?

- A. 0.07 microfarads
- B. 14.3 microfarads**
- C. 70 microfarads
- D. 1000 microfarads

With series capacitors the total capacitance will always be less than the smallest capacitor in the string. Or you can calculate it using $1/C_t = 1/C_1 + 1/C_2$ or $1/C_t = 1/50 + 1/20$ or $.020 + .050$ or $1/C_t = 0.070$ or 14.28

G5C13

Which of the following components should be added to a capacitor to increase the capacitance?

A capacitor in parallel

G5C14

Which of the following components should be added to an inductor to increase the inductance?

An inductor in series

G5C15

What is the total resistance of a 10 ohm, a 20 ohm, and a 50-ohm resistor connected in parallel? **5.9 ohms**

$1/R_t = 1/R_1 + 1/R_2 + 1/R_3$ or $1/R_t = 1/10 + 1/20 + 1/50$ or $.10 + .050 + .020$ or $1/r_t = 0.70$ or 5.88ohms

*Note that with parallel resistors the total resistance will always be less than the smallest resistor. The exam choices are 0.17 ohms, **5.9 ohms**, 80 ohms, and 1000 Ohms.*

G5C16

Why is the conductor of the primary winding of many voltage step-up transformers larger in diameter than the conductor of the secondary winding? **To accommodate the higher current of the primary**

G5C17

What is the value in nanofarads (nF) of a 22,000 picofarad (pF) capacitor? **22**

G5C18

What is the value in microfarads of a 4700 nanofarad (nF) capacitor? **4.7**

SUBELEMENT G6 – CIRCUIT COMPONENTS [2 Exam Questions – 2 Groups]

G6A – Resistors; capacitors; inductors; rectifiers; solid-state diodes and transistors; vacuum tubes; batteries

G6A01

What is the minimum allowable discharge voltage for maximum life of a standard 12-volt lead-acid battery?

10.5 volts

If a lead acid battery is discharged to below 10.5 volts it may not be able to recover and be recharged.

G6A02

What is an advantage of the low internal resistance of nickel-cadmium batteries? **High discharge current**

G6A03

What is the approximate junction threshold voltage of a germanium diode? **0.3 volts**

Threshold voltage is the voltage level where forward current will start to flow.

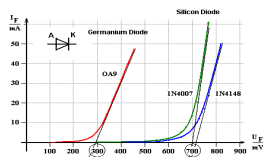

G6A04

Which of the following is an advantage of an electrolytic capacitor? **High capacitance for a given volume**

G6A05

What is the approximate junction threshold voltage of a conventional silicon diode? **0.7 volts**

See answer for G6A03.

G6A06

Which of the following is a reason not to use wire-wound resistors in an RF circuit?

The resistor's inductance could make circuit performance unpredictable

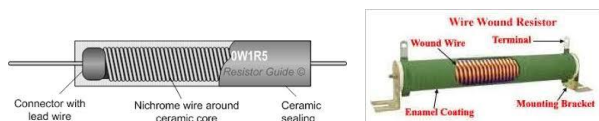

G6A07

What are the stable operating points for a bipolar transistor used as a switch in a logic circuit?

Its saturation and cutoff regions

Saturation is when the transistor has maximum current flow and cutoff is when the current flow is minimum.

G6A08

What is an advantage of using a ferrite core toroidal inductor?

- A. Large values of inductance may be obtained
- B. The magnetic properties of the core may be optimized for a specific range of frequencies
- C. Most of the magnetic field is contained in the core
- D. All these choices are correct

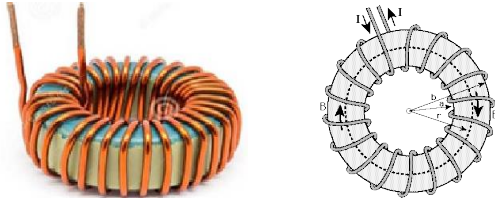

G6A09

Which of the following describes the construction of a MOSFET? **The gate is separated from the channel with a thin insulating layer**

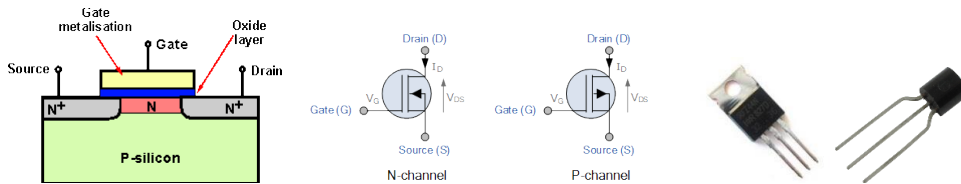

A MOSFET is a Metal Oxide Field Effect Transistor.

G6A10

Which element of a triode vacuum tube is used to regulate the flow of electrons between cathode and plate?

Control grid

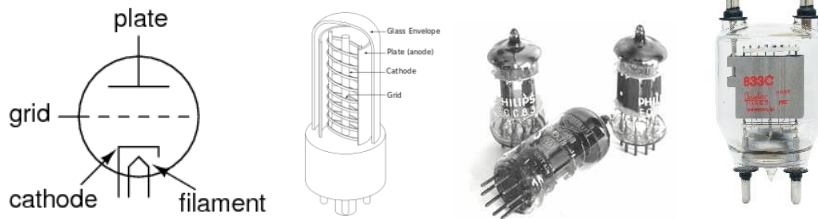

G6A11

What happens when an inductor is operated above its self-resonant frequency? **It becomes capacitive**

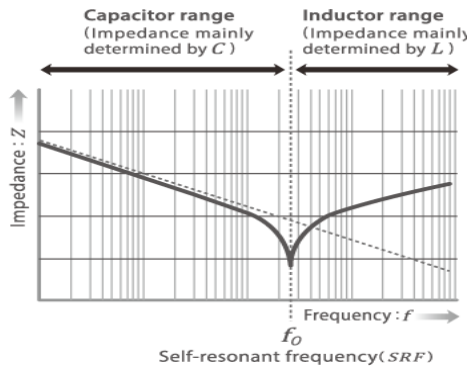

G6A12

What is the primary purpose of a screen grid in a vacuum tube? **To reduce grid-to-plate capacitance**

The screen grids purpose is to reduce capacitance that arises between the control grid and the plate. Such Parasitic capacitance can cause the tube's circuit to become self resonant at some frequencies, and it will reduce the tubes achievable gain at higher frequencies.

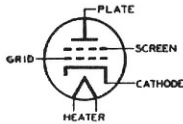

G6A13

Why is the polarity of applied voltages important for polarized capacitors?

- A. Incorrect polarity can cause the capacitor to short-circuit
- B. Reverse voltages can destroy the dielectric layer of an electrolytic capacitor
- C. The capacitor could overheat and explode
- D. All these choices are correct

G6A14

Which of the following is an advantage of ceramic capacitors as compared to other types of capacitors?

Comparatively low cost

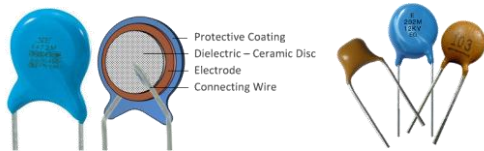

G6B – Analog and digital integrated circuits (ICs); microprocessors; memory; I/O devices; microwave ICs (MMICs); display devices; connectors; ferrite cores

G6B01

What determines the performance of a ferrite core at different frequencies? **The composition, or “mix,” of materials used**

G6B02

What is meant by the term MMIC? **Monolithic Microwave Integrated Circuit**

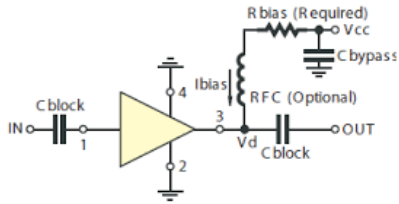

G6B03

Which of the following is an advantage of CMOS integrated circuits compared to TTL integrated circuits? **Low power consumption**

CMOS is an abbreviation for Complementary Metal Oxide Semiconductor

G6B04

What is meant by the term ROM? **Read Only Memory**

G6B05

What is meant when memory is characterized as non-volatile? **The stored information is maintained even if power is removed**

G6B06

What kind of device is an integrated circuit operational amplifier? **Analog**

G6B07

Which of the following describes a type N connector? **A moisture-resistant RF connector useful to 10 GHz**



G6B08

How is an LED biased when emitting light? **Forward biased**

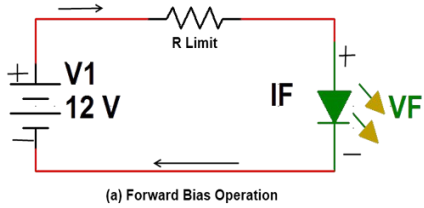

G6B09

Which of the following is a characteristic of a liquid crystal display? **It utilizes ambient or back lighting**



G6B10

How does a ferrite bead or core reduce common-mode RF current on the shield of a coaxial cable?

By creating an impedance in the current's path



G6B11

What is a type SMA connector? **A small threaded connector suitable for signals up to several GHz**



G6B12

Which of these connector types is commonly used for audio signals in Amateur Radio stations?

RCA Phono



G6B13

Which of these connector types is commonly used for RF connections at frequencies up to 150 MHz?

PL-259

Shown below are the PL259 plug (male) and SO239 Socket (female)



SUBELEMENT G7 – PRACTICAL CIRCUITS

[3 Exam Questions – 3 Groups]

G7A – Power supplies; schematic symbols

G7A01

What useful feature does a power supply bleeder resistor provide? **It ensures that the filter capacitors are discharged when power is removed**

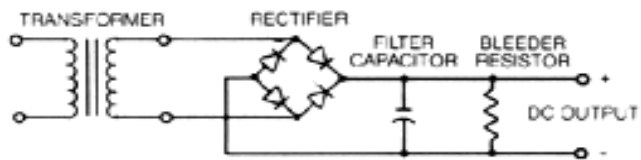

G7A02

Which of the following components are used in a power supply filter network? **Capacitors and inductors**

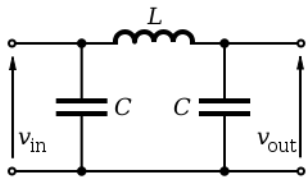

G7A03

Which type of rectifier circuit uses two diodes and a center-tapped transformer? **Full-wave**

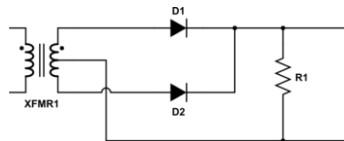

G7A04

What is an advantage of a half-wave rectifier in a power supply? **Only one diode is required**

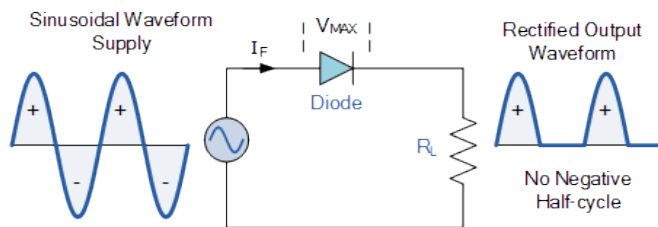

G7A05

What portion of the AC cycle is converted to DC by a half-wave rectifier? **180 degrees**

G7A06

What portion of the AC cycle is converted to DC by a full-wave rectifier? **360 degrees**

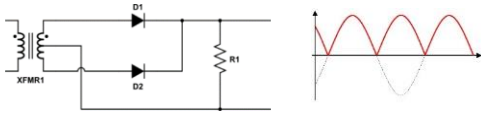

G7A07

What is the output waveform of an unfiltered full-wave rectifier connected to a resistive load?

A series of DC pulses at twice the frequency of the AC input

See graphic from above question

G7A08

Which of the following is an advantage of a switchmode power supply as compared to a linear power supply?

High-frequency operation allows the use of smaller components

In a switching power supply the raw 60 Hz line voltage is rectified and then the resulting DC is switched into a square wave at typically a 20 kHz rate. This higher frequency AC is passed through transformers that are much smaller and lighter since they do not need to pass the lower 60 Hz and the final rectified 20 kHz does not require the larger capacitors that would be needed for a linear power supply that is filtering 60 or 120 Hz (a full wave rectifier output is 120 Hz). See the waveform in G7A06

Switch mode power supply block diagram

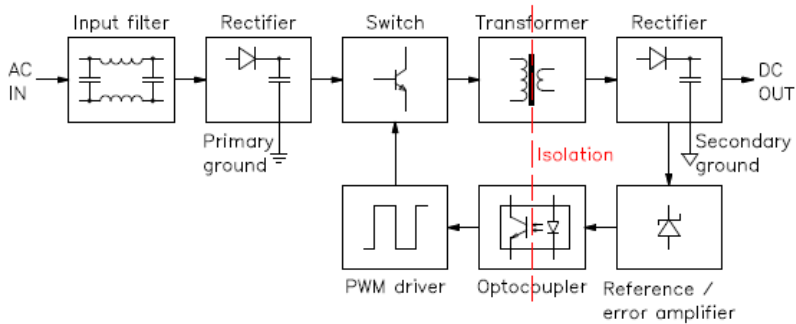

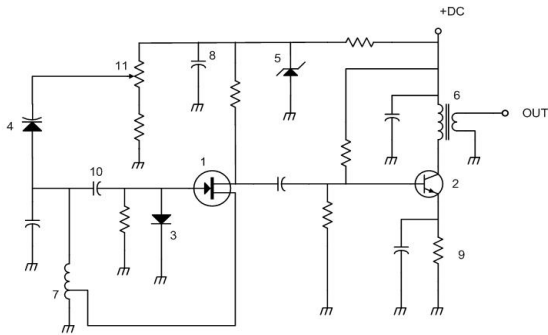

Figure G7-1

Graphic for questions G7A09 through G7A13

G7A09

Which symbol in figure G7-1 represents a field effect transistor? **Symbol 1**

G7A10

Which symbol in figure G7-1 represents a Zener diode? **Symbol 5**

G7A11

Which symbol in figure G7-1 represents an NPN junction transistor? **Symbol 2**

G7A12

Which symbol in Figure G7-1 represents a solid core transformer? **Symbol 6**

G7A13

Which symbol in Figure G7-1 represents a tapped inductor? **Symbol 7**

G7B – Digital circuits; amplifiers and oscillators

G7B01

What is the reason for neutralizing the final amplifier stage of a transmitter? **To eliminate self-oscillations**
This applies to tube type final amplifiers

Amplifier Class Operation Tutorial

Amplifiers are categorized by their type or class of operation, and circuit configuration.

CLASSES OF OPERATION (A AB, B & C)

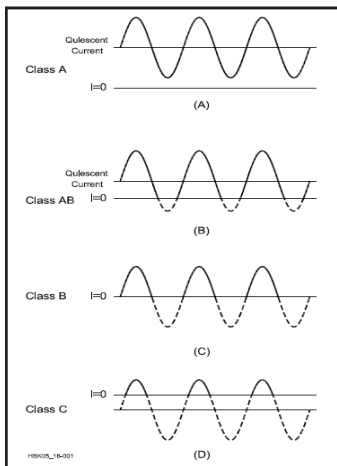

The class of operation of an amplifier stage is defined by its conduction angle, the angular portion of the sine wave drive cycle, in degrees, during which plate current (or collector or drain current in the case of transistors) flows. This, in turn, determines the amplifier's efficiency and linearity.

Class A: The conduction angle is 360° . DC bias and drive level are set so that the device is not driven to output current cutoff at any point in the driving- voltage cycle, so some device output current flows throughout the complete 360° of the cycle. Output voltage is generated by the variation of output current flowing through the load resistance. Maximum linearity and gain are achieved in a Class A amplifier, but the efficiency of the stage is low. Maximum theoretical efficiency is 50%, but 25 to 30% is more common in practice.

Class AB: The conduction angle is greater than 180° but less than 360° . In other words, dc bias and drive level are adjusted so device output current flows during appreciably more than half the drive cycle, but less than the whole drive cycle. Efficiency is much better than Class A, typically reaching 50-60% at peak output power. Class AB linearity and gain are not as good as that achieved in Class A but are very acceptable for even the most rigorous high-power SSB applications in Amateur Radio.

Class B: Conduction angle = 180° . Bias and RF drive are set so that the device is just cut off with no signal applied (see Fig 18.1C), and device output current flows during one half of the drive cycle. Efficiency commonly reaches as high as 65%, with fully acceptable linearity.

Class C: The conduction angle is much less than 180° —typically 90° . DC bias is adjusted so that the device is cut off when no drive signal is applied. Output current flows only during positive crests in the drive cycle, so it consists of pulses at the drive frequency. Efficiency is relatively high— up to 80%—but linearity is extremely poor. Thus, Class C amplifiers are not suitable for amplification of amplitude modulated signals such as SSB or AM but are quite satisfactory for use in on off keyed stages or with frequency or phase modulation. Gain is lower than for the previous classes of operation, typically 10-13 dB.

G7B02

Which of these classes of amplifiers has the highest efficiency? **Class C**

G7B03

Which of the following describes the function of a two-input AND gate? **Output is high only when both inputs are high**



G7B04

Which of the following describes the function of a two input NOR gate? **Output is low when either or both inputs are high**



G7B05

How many states does a 3-bit binary counter have? **8**

Count	Bit 3	Bit 2	Bit 1
0	0	0	0
1	0	0	1
2	0	1	0
3	0	1	1
4	1	0	0
5	1	0	1
6	1	1	0
7	1	1	1

G7B06

What is a shift register? **A clocked array of circuits that passes data in steps along the array**

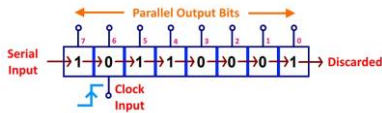

G7B07

Which of the following are basic components of a sine wave oscillator? **A filter and an amplifier operating in a feedback loop**

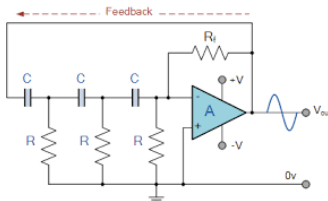

G7B08

How is the efficiency of an RF power amplifier determined? **Divide the RF output power by the DC input power**

G7B09

What determines the frequency of an LC oscillator? **The inductance and capacitance in the tank circuit**

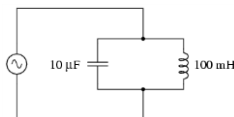

G7B10

Which of the following describes a linear amplifier? **An amplifier in which the output preserves the input waveform**

This would be a class A amplifier

G7B11

For which of the following modes is a Class C power stage appropriate for amplifying a modulated signal? **FM**

G7C – Receivers and transmitters; filters; oscillators

G7C01

Which of the following is used to process signals from the balanced modulator then send them to the mixer in some single sideband phone transmitters? **Filter**

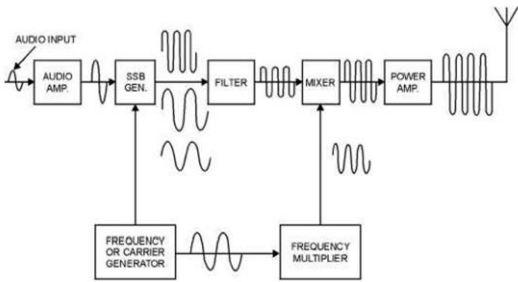

G7C02

Which circuit is used to combine signals from the carrier oscillator and speech amplifier then send the result to the filter in some single sideband phone transmitters? **Balanced modulator**

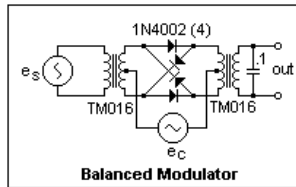

G7C03

What circuit is used to process signals from the RF amplifier and local oscillator then send the result to the IF filter in a superheterodyne receiver? **Mixer**

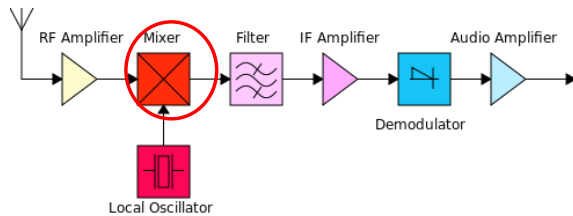

G7C04

What circuit is used to combine signals from the IF amplifier and BFO and send the result to the AF amplifier in some single sideband receivers? **Product detector**

A product detector is a type of demodulator used for AM and SSB signals. Rather than converting the envelope of the signal into the decoded waveform like an envelope detector, the product detector takes the product of the modulated signal and a local oscillator, hence the name. A product detector is a frequency mixer.

G7C05

Which of the following is an advantage of a direct digital synthesizer (DDS)? **Variable frequency with the stability of a crystal oscillator**

Direct digital synthesis (DDS) is a method of producing an analog waveform—usually a sine wave—by generating a time-varying signal in digital form and then performing a digital-to-analog conversion. Because operations within a DDS device are primarily digital, it can offer fast switching between output frequencies, fine frequency resolution, and operation over a broad spectrum of frequencies.

G7C06

What should be the impedance of a low-pass filter as compared to the impedance of the transmission line into which it is inserted? **About the same**

G7C07

What is the simplest combination of stages that implement a superheterodyne receiver?

HF oscillator. mixer. detector

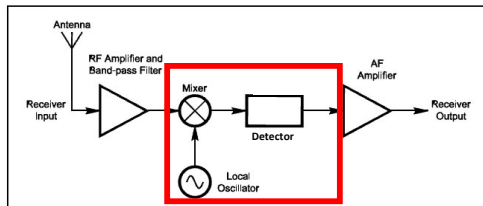

G7C08

What circuit is used in analog FM receivers to convert IF output signals to audio? **Discriminator**

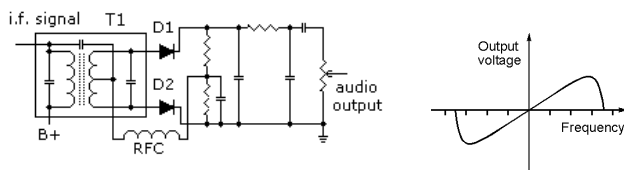

G7C09

What is the phase difference between the I and Q signals that software-defined radio (SDR) equipment uses for modulation and demodulation? **90 degrees**

G7C10

What is an advantage of using I and Q signals in software-defined radios (SDRs)?

All types of modulation can be created with appropriate processing.

G7C11

What is meant by the term “software-defined radio” (SDR)? **A radio in which most major signal processing functions are performed by software**

G7C12

What is the frequency above which a low-pass filter’s output power is less than half the input power?

Notch frequency

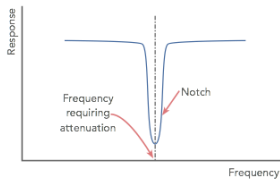

G7C13

What term specifies a filter’s maximum ability to reject signals outside its passband? **Ultimate rejection**

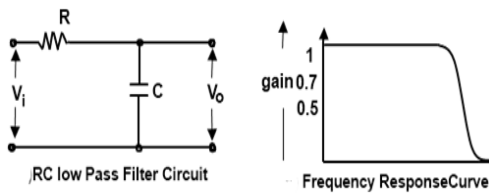

G7C14

The bandwidth of a band-pass filter is measured between what two frequencies? **Upper and lower half-power**

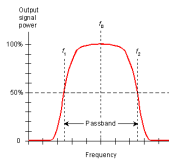

G7C15

What term specifies a filter’s attenuation inside its passband? **Insertion loss**

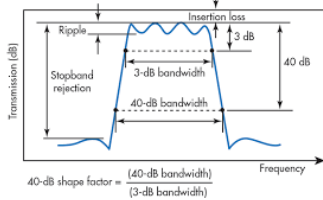

G7C16

Which of the following is a typical application for a Direct Digital Synthesizer? **A high-stability variable frequency oscillator in a transceiver**

SUBELEMENT G8 – SIGNALS AND EMISSIONS

[3 Exam Questions – 3 Groups]

G8A – Carriers and modulation: AM; FM; single sideband; modulation envelope; digital modulation; overmodulation

G8A01

How is an FSK signal generated? **By changing an oscillator's frequency directly with a digital control signal**

FSK is the process of shifting (modulating) an analog carrier frequency at a digital rate. FSK closely resembles standard FM (Frequency Modulation). With FSK, the modulating signal is not a sinusoidal signal but a series of dc pulses that vary between two discrete voltage levels. FSK is often used in modems.

G8A02

What is the name of the process that changes the phase angle of an RF signal to convey information?

Phase modulation

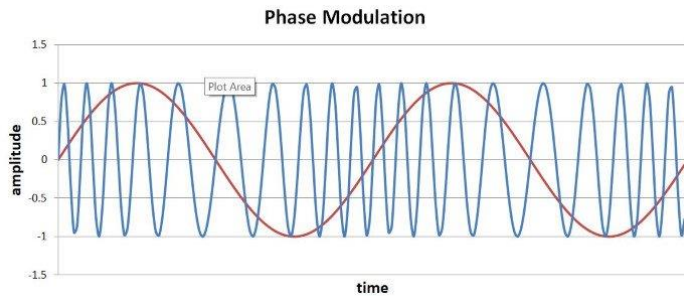

G8A03

What is the name of the process that changes the instantaneous frequency of an RF wave to convey information? **Frequency modulation**

G8A04

What emission is produced by a reactance modulator connected to a transmitter RF amplifier stage?

Phase modulation

G8A05

What type of modulation varies the instantaneous power level of the RF signal? **Amplitude modulation**

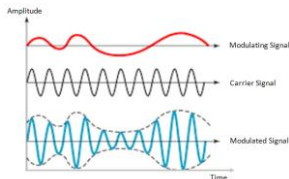

G8A06

Which of the following is characteristic of QPSK31?

- A. It is sideband sensitive
- B. Its encoding provides error correction
- C. Its bandwidth is approximately the same as BPSK31
- D. All these choices are correct**

G8A06

Which of the following is characteristic of QPSK31? **The bandwidth is slightly higher than BPSK31**

G8A07

Which of the following phone emissions uses the narrowest bandwidth? **Single sideband**

G8A08

Which of the following is an effect of overmodulation? **Excessive bandwidth**

G8A09

What type of modulation is used by the FT8 digital mode? **8-tone frequency shift keying**

G8A10

What is meant by the term “flat-topping,” when referring to a single sideband phone transmission?

Signal distortion caused by excessive drive

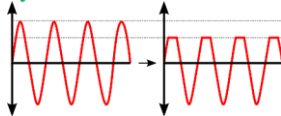

G8A11

What is the modulation envelope of an AM signal? **The waveform created by connecting the peak values of the modulated signal**

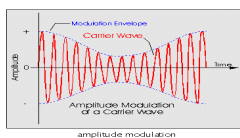

G8A12

Which of the following narrow-band digital modes can receive signals with very low signal-to-noise ratios?

FT8

G8B – Frequency mixing; multiplication; bandwidths of various modes; deviation; duty cycle; intermodulation

G8B01

Which mixer input is varied or tuned to convert signals of different frequencies to an intermediate frequency (IF)? **Local oscillator**

G8B02

If a receiver mixes a 13.800 MHz VFO with a 14.255 MHz received signal to produce a 455 kHz intermediate frequency (IF) signal, what type of interference will a 13.345 MHz signal produce in the receiver?

Image response

Both frequencies will give a 455 kHz if frequency When mixed they give the sum and difference frequencies for the two inputs. $14.255 - 13.800 = 455 \text{ kHz}$ and $13.800 - 13.345 = 455 \text{ kHz}$

G8B03

What is another term for the mixing of two RF signals? **Heterodyning**

G8B04

What is the stage in a VHF FM transmitter that generates a harmonic of a lower frequency signal to reach the desired operating frequency? **Multiplier**

G8B05

What is the approximate bandwidth of a PACTOR-III signal at maximum data rate? **2300 Hz**

2300 HZ is the higher value in the multiple-choice answers. Pactor III is a high data rate transmission so it is logical that it would require the highest bandwidth (Not exceeding the 2.8 KHz phone signal bandwidth).

G8B06

What is the total bandwidth of an FM phone transmission having 5 kHz deviation and 3 kHz modulating frequency? **16 kHz**

The bandwidth is the max deviation, which is plus or minus 5 KHz plus the maximum modulating frequency which is 3 KHz for a total deviation of plus and minus 8 KHz for a total occupied bandwidth of 16 KHz.

$$\text{Total bandwidth} = 2 \times (f_m (\text{modulation}) + f_{(\text{deviation})}) \text{ or } 2 (3 \text{ KHz} + 5 \text{ kHz}) \text{ or } 2 (8 \text{ KHz}) \text{ or } 16 \text{ KHz}$$

G8B07

What is the frequency deviation for a 12.21 MHz reactance modulated oscillator in a 5 kHz deviation, 146.52 MHz FM phone transmitter? **416.7 Hz**

12.21 MHz must be multiplied by 12 (146.52/12.21) to achieve a 146.52 MHz signal. Since the deviation on the 12.21 signal is also multiplied the actual deviation at 12.21 MHz would be 1/12 of the desired modulation or 5 KHz ÷ 12 or 416.66 Hz.

G8B08

Why is it important to know the duty cycle of the mode you are using when transmitting?

Some modes have high duty cycles that could exceed the transmitter's average power rating

A 100-watt SSB transmitter will not be capable of 100 watts CW or digital signals. The average power for a 100-watt pep transmission is significantly lower than 100 Watts. Typically about 40 watts.

G8B09

Why is it good to match receiver bandwidth to the bandwidth of the operating mode?

It results in the best signal-to-noise ratio

G8B10

What is the relationship between transmitted symbol rate and bandwidth? **Higher symbol rates require wider bandwidth**

G8B11

What combination of a mixer's Local Oscillator (LO) and RF input frequencies is found in the output?

The sum and difference

G8B12

What process combines two signals in a non-linear circuit or connection to produce unwanted spurious outputs?

Intermodulation

Intermodulation (IM) or intermodulation distortion (IMD) is the amplitude modulation of signals containing two or more different frequencies, caused by nonlinearities or time variance in a system.

G8C – Digital emission modes

G8C01

On what band do amateurs share channels with the unlicensed Wi-Fi service? **2.4 GHz**

G8C02

Which digital mode is used as a low-power beacon for assessing HF propagation? **WSPR**

G8C03

What part of a packet radio frame contains the routing and handling information? **Header**

G8C04

Which of the following describes Baudot code? **A 5-bit code with additional start and stop bits**

G8C05

In the PACTOR protocol, what is meant by a NAK response to a transmitted packet? **The receiver is requesting the packet be retransmitted**

G8C06

What action results from a failure to exchange information due to excessive transmission attempts when using PACTOR or WINMOR? **The connection is dropped**

G8C07

How does the receiving station respond to an ARQ data mode packet containing errors? **It requests the packet be retransmitted**

Automatic repeat request (ARQ), also known as automatic repeat query, is an error-control method for data transmission that uses acknowledgements (messages sent by the receiver indicating that it has correctly received a packet) and timeouts (specified periods of time allowed to elapse before an acknowledgment is to be received) to achieve reliable data transmission over an unreliable service.

G8C08

Which of the following statements is true about PSK31? **Upper case letters use longer Varicode bit sequences and thus slow down transmission**

G8C09

What does the number 31 represent in "PSK31"? **The approximate transmitted symbol rate**

G8C10

How does forward error correction (FEC) allow the receiver to correct errors in received data packets?

By transmitting redundant information with the data

G8C11

How are the two separate frequencies of a Frequency Shift Keyed (FSK) signal identified?

Mark and space

G8C12

Which type of code is used for sending characters in a PSK31 signal? **Varicode**

Just like Morse Code more frequently used character are transmitted with shorter code to speed up communication.

G8C13

What is indicated on a waterfall display by one or more vertical lines on either side of a digital signal?

Overmodulation

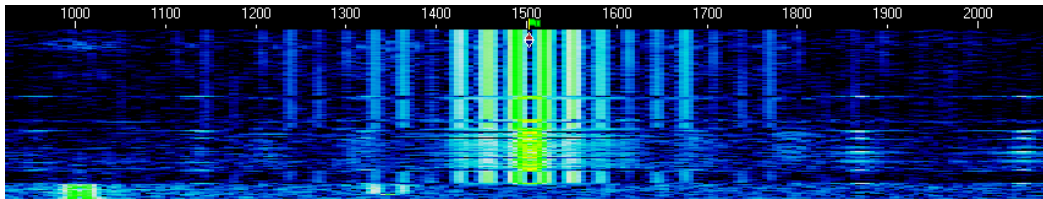

G8C14

Which of the following describes a waterfall display? **Frequency is horizontal, signal strength is intensity, time is vertical**

SUBELEMENT G9 – ANTENNAS AND FEED LINES
[4 Exam Questions – 4 Groups]

G9A – Antenna feed lines: characteristic impedance and attenuation; SWR calculation, measurement, and effects; matching networks

G9A01

Which of the following factors determine the characteristic impedance of a parallel conductor antenna feed line? **The distance between the centers of the conductors and the radius of the conductors**

G9A02

What are the typical characteristic impedances of coaxial cables used for antenna feed lines at amateur stations? **50 and 75 ohms**

G9A03

What is the typical characteristic impedance of “window line” parallel transmission line? **450 ohms**



G9A04

What might cause reflected power at the point where a feed line connects to an antenna? **A difference between feed-line impedance and antenna feed-point impedance**

G9A05

How does the attenuation of coaxial cable change as the frequency of the signal it is carrying increases? **Attenuation increases**

G9A06

In what units is RF feed line loss usually expressed? **Decibels per 100 feet**

G9A07

What must be done to prevent standing waves on an antenna feed line? **The antenna feed point impedance must be matched to the characteristic impedance of the feed line**

G9A08

If the SWR on an antenna feed line is 5 to 1, and a matching network at the transmitter end of the feed line is adjusted to 1 to 1 SWR, what is the resulting SWR on the feed line? **5 to 1**

G9A09

What standing wave ratio will result when connecting a 50-ohm feed line to a non-reactive load having 200 ohm impedance? **4:1**

G9A10

What standing wave ratio will result when connecting a 50-ohm feed line to a non-reactive load having 10 ohm impedance? **5:1**

G9A11

What standing wave ratio will result when connecting a 50-ohm feed line to a non-reactive load having 50 ohm impedance? **1:1**

G9A12

What is the interaction between high standing wave ratio (SWR) and transmission line loss?

If a transmission line is lossy, high SWR will increase the loss

G9A13

What is the effect of transmission line loss on SWR measured at the input to the line? **The higher the**

transmission line loss, the more the SWR will read artificially low

G9B – Basic antennas

G9B01

What is one disadvantage of a directly fed random-wire HF antenna? **You may experience RF burns when touching metal objects in your station**

G9B02

Which of the following is a common way to adjust the feed-point impedance of a quarter wave ground-plane vertical antenna to be approximately 50 ohms? **Slope the radials downward**



G9B03

Which of the following best describes the radiation pattern of a quarter-wave, ground-plane vertical antenna?

Omnidirectional in azimuth

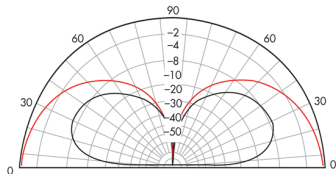

G9B04

What is the radiation pattern of a dipole antenna in free space in a plane containing the conductor?

It is a figure-eight at right angles to the antenna

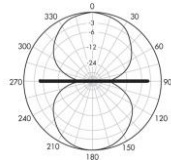

G9B05

How does antenna height affect the horizontal (azimuthal) radiation pattern of a horizontal dipole HF antenna?

If the antenna is less than 1/2 wavelength high, the azimuthal pattern is almost omnidirectional

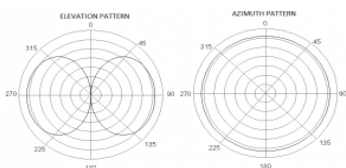

G9B06

Where should the radial wires of a ground-mounted vertical antenna system be placed? **On the surface of the Earth or buried a few inches below the ground**

G9B07

How does the feed-point impedance of a 1/2 wave dipole antenna change as the antenna is lowered below 1/4 wave above ground? **It steadily decreases**

G9B08

How does the feed point impedance of a 1/2 wave dipole change as the feed point is moved from the center toward the ends? **It steadily increases**

G9B09

Which of the following is an advantage of a horizontally polarized as compared to a vertically polarized HF antenna? **Lower ground reflection losses**

G9B10

What is the approximate length for a 1/2 wave dipole antenna cut for 14.250 MHz? **33 feet**

*Wavelength (M) = 300/14.250 or 21.052 meters therefore 1/2 wavelength would be 10.526 Meters
There are 3.05 feet in a meter so to find the answer in feet multiply 10.526 by 3.05 to get 32.10 Feet*

G9B11

What is the approximate length for a 1/2 wave dipole antenna cut for 3.550 MHz? **132 feet**

*Wavelength (M) = 300/3.550 or 84.388 meters therefore 1/2 wavelength would be 41.194 Meters
There are 3.05 feet in a meter so to find the answer in feet multiply 41.194 by 3.05 to get 128.69 Feet*

G9B12

What is the approximate length for a 1/4 wave vertical antenna cut for 28.5 MHz? **8 feet**

*Wavelength (M) = 300/28.5 or 10.526 meters therefore 1/4 wavelength would be 2.6316 Meters
There are 3.05 feet in a meter so to find the answer in feet multiply 2.6316 by 3.05 to get 8.0263 Feet*

G9C – Directional antennas

G9C01

Which of the following would increase the bandwidth of a Yagi antenna? **Larger-diameter elements**

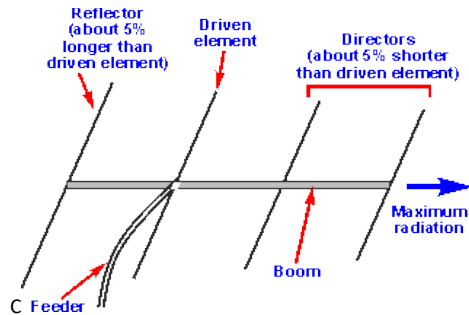

G9C02

What is the approximate length of the driven element of a Yagi antenna? **1/2 wavelength**

G9C03

How do the lengths of a three-element Yagi reflector and director compare to that of the driven element?

The reflector is longer, and the director is shorter

See answer in G9C01

G9C04

How does antenna gain stated in dBi compare to gain stated in dBd for the same antenna? **dBi gain figures are 2.15 dB higher than dBd gain figures**

dBi is dB isotropic. An isotropic radiator is a theoretical point source of electromagnetic waves which radiates the same intensity of radiation in all directions. It has no preferred direction of radiation. It radiates uniformly in all directions over a sphere centered on the point source.

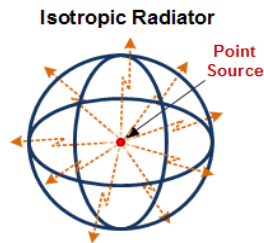

G9C05

How does increasing boom length and adding directors affect a Yagi antenna? **Gain increases**

G9C06

What configuration of the loops of a two-element quad antenna must be used for the antenna to operate as a beam antenna, assuming one of the elements is used as a reflector? **The reflector element must be approximately 5 percent longer than the driven element**

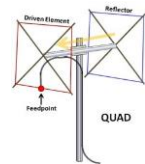

G9C07

What does “front-to-back ratio” mean in reference to a Yagi antenna? **The power radiated in the major radiation lobe compared to that in the opposite direction**

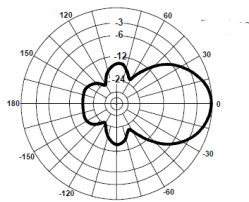

G9C08

What is meant by the “main lobe” of a directive antenna? **The direction of maximum radiated field strength from the antenna**

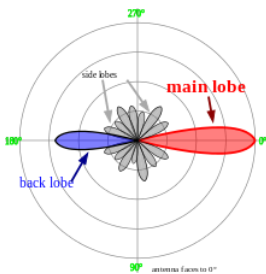

G9C09

How does the gain of two three-element, horizontally polarized Yagi antennas spaced vertically 1/2 wavelength apart typically compare to the gain of a single three-element Yagi? **Approximately 3 dB higher**

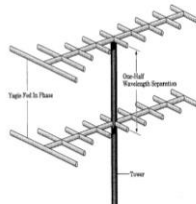

G9C10

Which of the following can be adjusted to optimize forward gain, front-to-back ratio, or SWR bandwidth of a Yagi antenna?

- A. The physical length of the boom
- B. The number of elements on the boom
- C. The spacing of each element along the boom
- D. All these choices are correct

G9C11

Which HF antenna would be the best to use for minimizing interference? **A directional antenna**

G9C12

Which of the following is an advantage of using a gamma match with a Yagi antenna? **It does not require that the driven element be insulated from the boom**

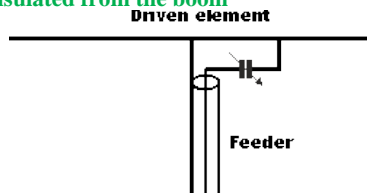

G9C13

Approximately how long is each side of the driven element of a quad antenna? **1/4 wavelength**

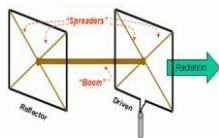

G9C14

How does the forward gain of a two-element quad antenna compare to the forward gain of a three-element Yagi antenna? **About the same**

G9C15

What is meant by the terms dBi and dBd when referring to antenna gain? **dBi refers to an isotropic antenna, dBd refers to a dipole antenna**

G9C16

What is a beta or hairpin match? **It is a shorted transmission line stub placed at the feed point of a Yagi antenna to provide impedance matching**

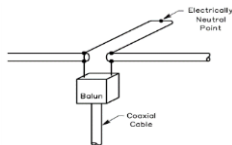

G9D – Specialized antennas

G9D01

Which of the following antenna types will be most effective as a Near Vertical Incidence Skywave (NVIS) antenna for short-skip communications on 40 meters during the day? **A horizontal dipole placed between 1/10 and 1/4 wavelength above the ground**

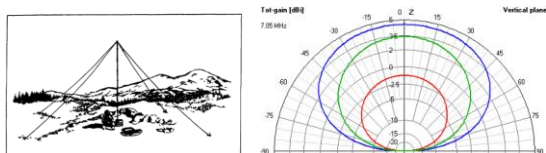

G9D02

What is the feed-point impedance of an end-fed half-wave antenna? **Very high**

G9D03

In which direction is the maximum radiation from a portable VHF/UHF “halo” antenna? **Omnidirectional in the plane of the halo**



G9D04

What is the primary purpose of antenna traps? **To permit multiband operation**

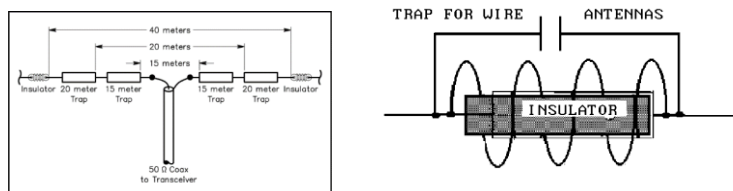

G9D05

What is an advantage of vertical stacking of horizontally polarized Yagi antennas? **It narrows the main lobe in elevation**

G9D06

Which of the following is an advantage of a log periodic antenna? **Wide bandwidth**

G9D07

Which of the following describes a log periodic antenna? **Element length and spacing vary logarithmically along the boom**

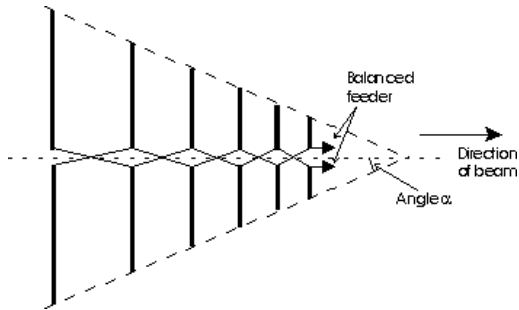

G9D08

How does a "screwdriver" mobile antenna adjust its feed-point impedance? **By varying the base loading inductance**

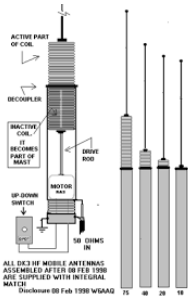

G9D09

What is the primary use of a Beverage antenna? **Directional receiving for low HF bands**

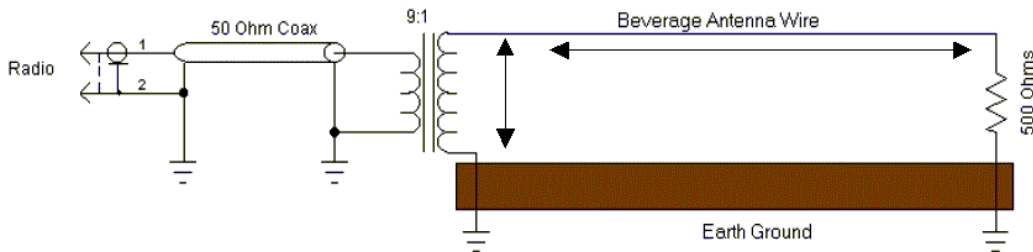

The Beverage antenna is a directional long-wire receiving antenna mainly used in the low frequency and medium frequency radio bands. For a Beverage to Work reasonably well you need at least 1 wavelength of wire. On 160 meters that's 490 feet of wire in as straight a line as possible. Two wavelengths works better

G9D10

In which direction or directions does an electrically small loop (less than 1/3 wavelength in circumference) have nulls in its radiation pattern? **Broadside to the loop**

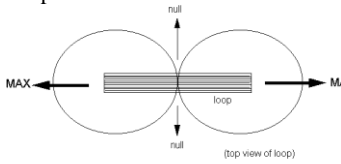

G9D11

Which of the following is a disadvantage of multiband antennas? **They have poor harmonic rejection**

G9D12

What is the common name of a dipole with a single central support? **Inverted V**

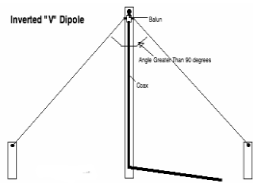

G9D13

What is the combined vertical and horizontal polarization pattern of a multi-wavelength, horizontal loop antenna? **Virtually omnidirectional with a lower peak vertical radiation angle than a dipole**

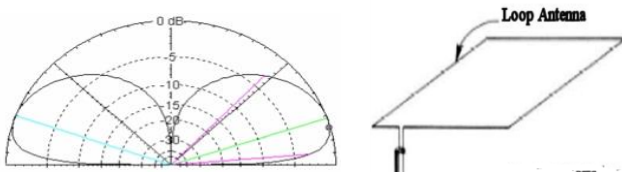

SUBELEMENT G0 – ELECTRICAL AND RF SAFETY
[2 Exam Questions – 2 Groups]

G0A – RF safety principles, rules and guidelines; routine station evaluation

G0A01

What is one way that RF energy can affect human body tissue? **It heats body tissue**

G0A02

Which of the following properties is important in estimating whether an RF signal exceeds the maximum permissible exposure (MPE)?

- A. Its duty cycle**
- B. Its frequency**
- C. Its power density**
- D. All these choices are correct**

G0A03 [97.13(c)(1)]

How can you determine that your station complies with FCC RF exposure regulations?

- A. By calculation based on FCC OET Bulletin 65**
- B. By calculation based on computer modeling**
- C. By measurement of field strength using calibrated equipment**
- D. All these choices are correct**

G0A04

What does “time averaging” mean in reference to RF radiation exposure? **The total RF exposure averaged over a certain time**

G0A05

What must you do if an evaluation of your station shows RF energy radiated from your station exceeds permissible limits? **Take action to prevent human exposure to the excessive RF fields**

G0A06

What precaution should be taken when installing a ground-mounted antenna? **It should be installed such that it is protected against unauthorized access**

G0A07

What effect does transmitter duty cycle have when evaluating RF exposure? **A lower transmitter duty cycle permits greater short-term exposure levels**

G0A08

Which of the following steps must an amateur operator take to ensure compliance with RF safety regulations when transmitter power exceeds levels specified in FCC Part 97.13? **Perform a routine RF exposure evaluation**

G0A09

What type of instrument can be used to accurately measure an RF field? **A calibrated field strength meter with a calibrated antenna**



G0A10

What is one thing that can be done if evaluation shows that a neighbor might receive more than the allowable limit of RF exposure from the main lobe of a directional antenna? **Take precautions to ensure that the antenna cannot be pointed in their direction**

G0A11

What precaution should you take if you install an indoor transmitting antenna? **Make sure that MPE limits are not exceeded in occupied areas**

MPE Limits can be found online and in the ARRL Publication RF Exposure and You

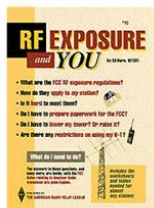

G0B – Station safety: electrical shock, safety grounding, fusing, interlocks, wiring, antenna and tower safety

G0B01

Which wire or wires in a four-conductor connection should be attached to fuses or circuit breakers in a device operated from a 240 VAC single phase source? **Only the two wires carrying voltage**

G0B02

According to the National Electrical Code, what is the minimum wire size that may be used safely for wiring with a 20-ampere circuit breaker? **AWG number 12**

(Amperes)	Copper
15	14
20	12
30	10

G0B03

Which size of fuse or circuit breaker would be appropriate to use with a circuit that uses AWG number 14 wiring? **15 amperes**

G0B04

Which of the following is a primary reason for not placing a gasoline-fueled generator inside an occupied area? **Danger of carbon monoxide poisoning**

G0B05

Which of the following conditions will cause a Ground Fault Circuit Interrupter (GFCI) to disconnect the 120 or 240 Volt AC line power to a device? **Current flowing from one or more of the voltage-carrying wires directly to ground**

G0B06

Which of the following is covered by the National Electrical Code? **Electrical safety inside the ham shack**

G0B07

Which of these choices should be observed when climbing a tower using a safety belt or harness? **Confirm that the belt is rated for the weight of the climber and that it is within its allowable service life**

G0B08

What should be done by any person preparing to climb a tower that supports electrically powered devices? **Make sure all circuits that supply power to the tower are locked out and tagged**

G0B09

Which of the following is true of an emergency generator installation? **The generator should be located in a well-ventilated area**

G0B10

Which of the following is a danger from lead-tin solder? **Lead can contaminate food if hands are not washed carefully after handling the solder**

G0B11

Which of the following is good practice for lightning protection grounds? **They must be bonded together with all other grounds**

G0B12

What is the purpose of a power supply interlock? **To ensure that dangerous voltages are removed if the cabinet is opened**

G0B13

What must you do when powering your house from an emergency generator? **Disconnect the incoming utility power feed**

G0B14

What precaution should you take whenever you adjust or repair an antenna? **Turn off the transmitter and disconnect the feed line**

Useful information

Series and parallel resistors

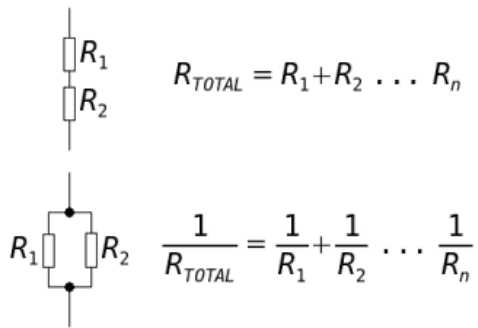

Series Inductances

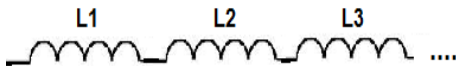

$$L_{total} = L_1 + L_2 + L_3 \dots$$

Parallel Inductances

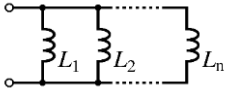
$$L_{total} = \frac{1}{\frac{1}{L_1} + \frac{1}{L_2} + \dots + \frac{1}{L_n}}$$

Parallel Capacitances

$$C_{total} = C_1 + C_2 + \dots C_n$$

Series Capacitances

$$C_{total} = \frac{1}{\frac{1}{C_1} + \frac{1}{C_2} + \dots + \frac{1}{C_n}}$$

dB from Power ratio:

$dB = 10 (\log (P1/P2))$

Example: $dB = 10 (\log (5/10))$ or $10(\log (.5))$ or $10 (-.301)$ or $-3 dB$
 $dB = 10 (\log (10/5))$ or $10(\log (2))$ or $10 (.301)$ or $+3 dB$

dB from voltage ratio:

$dB = 10 (\log (V1/V2))$

Example: $dB = 20 (\log (5/10))$ or $20(\log (.5))$ or $20 (-.301)$ or $-6 dB$
 $dB = 20 (\log (10/5))$ or $20(\log (2))$ or $20 (.301)$ or $+6 dB$

Power ratio from dB:

$Ratio = 10^{(dB/10)}$

Example: $Ratio = 10^{(dB/10)}$ or $10^{(3/10)}$ or $10^{(.3)}$ or 1.9999
 $Ratio = 10^{(dB/10)}$ or $10^{(-3/10)}$ or $10^{(-.3)}$ or 0.50

Voltage ratio from dB:

$Ratio = 10^{(dB/20)}$

Example: $Ratio = 10^{(dB/20)}$ or $10^{(6/20)}$ or $10^{(.3)}$ or 1.9999
 $Ratio = 10^{(dB/20)}$ or $10^{(-3/20)}$ or $10^{(-.3)}$ or $.50$

Note: to solve for a negative exponent press **10^x** key to see $10^{()}$ then press the **+/- key** to see $10^{(-)}$ then **enter -.3** to see $10^{(-.3)}$ then press the **enter/=** key to see the answer **.501**

Triangles

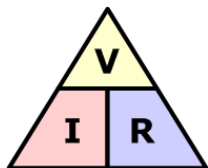

Ohms Law Triangle

V = Voltage in Volts
I = Current in Amperes
R = Resistance in Ohms

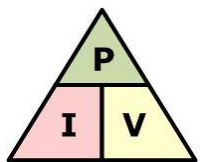

Power Law Triangle

V = Voltage in Volts
I = Current in Amperes
P = Power in Watts

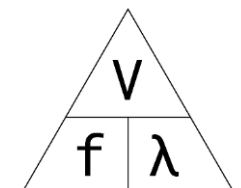

Wavelength Triangle

V = Velocity of Light (300,000,000 meters per second)
f = Frequency in Hz
λ = Wavelength in Meters

Decibel Calculations:

By Calculation:

$dB = 10 (\log(P1 \div P2))$ or $dB = 10(\log (10 \div 5))$ or $dB = 10(\log (2))$ or $dB = 10 (.3010)$ or $dB = 3.01$

By using the table

+	dB	-
2 x	3	.5 x
10 x	10	.1 x

One half wavelength in feet:

One Half wavelength = $468 \div$ Frequency in Mega Hertz

One Half Wave length in Inches:

One Half wavelength = $(492 \div$ Frequency in Mega Hertz) x (12)

